



The TruWood Collection



| | |
|--|-----------|
| CONTACT PAGE | 03 |
| ABOUT TRUWOOD | 04 |
| SPEC SHEETS | 08 |
| Reversible and Non-Reversible Trim | 09 |
| Cottage Lap Siding | 11 |
| Self-Aligning Lap Siding | 13 |
| Cedar Shake Lap Siding | 15 |
| Sure Lock Lap Siding | 17 |
| Designer Shake Lap Siding | 19 |
| Old Mill Shingle Lap Siding | 21 |
| Bevel Edge Lap Siding | 23 |
| Panel Siding and Soffit | 25 |
| Adobe Panel Siding | 27 |
| ValuForm Bender Board Concrete Form | 29 |
| INSTALLS | 30 |
| TruWood Trim | 31 |
| Premium Lap Siding | 37 |
| Bevel Edge Lap & Self-Aligning Lap Siding | 43 |
| Sure Lock Lap Siding | 49 |
| Old Mill Shingle and Designer Shake Lap Siding | 55 |
| Panel Siding, Soffit and Overhead Application | 61 |
| WARRANTY | 67 |
| ICC-ES EVALUATION REPORT | 70 |
| TRUWOOD WUI LISTING | 75 |

Tru teamwork.

Meet the people behind the TruWood promise. Give one of us a call and tell us how we can help your home dreams come true.

SCOTT WESSEL

Inside Sales Representative
541.885.3231
800.417.3674
SWessel@collinsco.com

CHRIS DANIEL

Regional Sales Representative
CO, IA, KS, NE, OK, SD, TX, WY
303.503.6311
CDaniel@collinsco.com

BRETT BLEICHRODT

Sales Manager
MI, NM, W. TX
303.895.8556
BBleichrodt@collinsco.com

TOM SCOTT

TruWood Product Performance
503.826.5239
800.329.1219 x5239
TScott@collinsco.com

LORI WORTHINGTON

Regional Sales Representative
AZ, CA, NV, OR
541.882.8319
LWorthington@collinsco.com

BILL MOYER

Regional Sales Representative
ID, MT, ND, UT, WA
208.860.3106
WMoyer@collinsco.com

Tru availability.

TruWood is available in 19 western states. Check out links below for dealers, distributors and Home Depot locations, and to see our quality and character in person.

[TRUWOOD DEALERS](#)

[TRUWOOD
WHOLESALE
DISTRIBUTORS](#)

[PRODUCT VISUALIZER](#)

[VALUFORM DEALERS](#)



Tru Distinction.

With a legacy of excellence and products engineered to last, TruWood leads the way in beautiful, sustainable and durable engineered wood siding and trim. Discover how our Klamath Falls, Oregon-based company has earned a reputation for unparalleled commitment to our customers, our quality and our planet. Find what's Tru to you.



ECOGUARD®

Zinc borate process resists mildew, rot and termite damage.

CHARACTER

Rough sawn cedar texture and reversible trim lend distinctive style.

DURABILITY

Quality engineered wood surface and core with our advanced formulated binders and waxes for long-term durability.

CONSISTENCY

Produced with in-line process controls for production consistency.

RELIABILITY

The assurance of quality and reliability, backed by our 30-year transferable warranty.

EASY AND SAFE

Easy to install using normal woodworking tools. No silica dust.

VERSATILITY

The most complete selection of styles and profiles in the industry. We offer a variety of patterns, textures, lengths and widths for maximum design flexibility and creativity.

MATCHING TRIM

Reversible and Non-Reversible designs available. 3/4 in. (actual) is non-reversible and primed three sides. 1 in. (actual) is reversible with Old Mill® texture on one side, smooth on the other and primed all four sides. 16 ft. lengths available in 2-1/2 in to 11-1/4 in widths (actual).

WEATHER-RESISTANCE

Products factory-primed with industry-leading coating for added weather protection, ready for your choice of paint color. All backed by our 5-year primer warranty.

GREEN

Commitment to the planet begins with products manufactured from residual wood fiber and continues with sustainable forestry practices certified by FSC®



1/2 in. COTTAGE LAP® SIDING



7/16 in. OLD MILL® PANEL SIDING



1/2 in. SELF-ALIGNING LAP SIDING



1/2 in. SURE LOCK™ LAP SIDING*



1/2 in. CHANNEL RUSTIC™ LAP SIDING

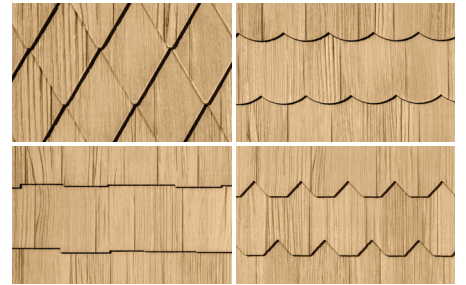

1/2 in. DESIGNER SHAKE® LAP SIDING

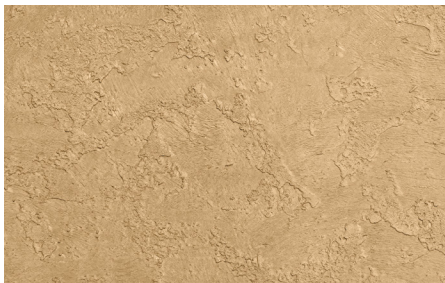

1/2 in. ADOBE™ PANEL SIDING



1/2 in. 808 OLD MILL® PANEL SIDING



OLD MILL® SHINGLE LAP SIDING

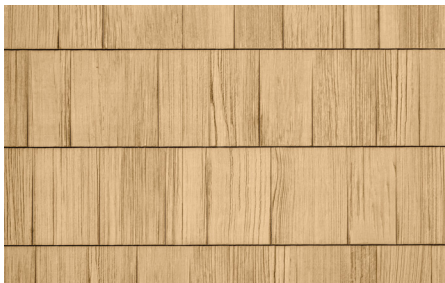

1/2 in. CEDAR SHAKE LAP SIDING



1/2 in. SURE LOCK™ SIX COTTAGE LAP® SIDING*



REVERSIBLE AND NON-REVERSIBLE TRIM

Tru Character. Our six-decade dedication to quality is evident in each and every product we produce. We capture the beauty of wood to create distinctive character, architectural versatility and eye-catching curb appeal.



* SURE LOCK: TRUWOOD'S UNIQUE CONCEALED NAILING SYSTEM

Design dreams come Tru.

Looking for the finishing touch that fits your vision and installs like a dream? TruWood's Trim offers an unbeatable combination of beauty, durability and ease.

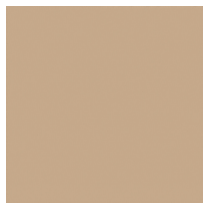

Available in a variety of sizes, TruWood Trim is ideal for band boards, batten, corner boards, cornice, door trim, fascia, frieze boards, rake boards, soffit and window trim. And because it's simple to install, getting the look you want has never been easier.



Visualize Tru curb appeal.



Preview what Tru can do for you. See TruWood products on sample homes with our interactive Visualizer at Visualizer.TruWoodSiding.com.

TruWood[®]
SIDING | TRIM

TruWood is available in 19 western states. Visit TruWoodSiding.com or call **800.417.3674** for dealers, distributors, home center locations, warranty and installation instructions, a siding calculator, or for more information. You'll find what sets us apart. And what can set your home apart.



CAL. PROP 65 WARNING: Use of this product may result in exposure to wood dust, known to the State of California to cause cancer.

Siding and Trim Specifications and Coverage

| Siding Size | Thickness | Pieces / Bundle | Pieces / Unit | Maximum Exposure in inches | Sq. ft. Coverage / Piece | Actual | Approx. Coverage Sq. ft. / Unit* | Approx. Sq. ft. Needed to Cover 1000 Sq. ft. of Wall Area* | Approx. Weight Lbs. / Unit |
|---|-----------|-----------------|---------------|----------------------------|--------------------------|----------------------------------|----------------------------------|--|----------------------------|
| | | | | | | | | | |
| OLD MILL® LAP | | | | | | | | | |
| 6 in. x 16 ft. Bevel Edge Lap | 7/16 in. | 6 | 336 | 5 | 6.67 | 0.395 in. x 6 in. x 16 ft. | 2128 | 1260 | 4420 |
| 8 in. x 16 ft. Bevel Edge Lap | 7/16 in. | 6 | 252 | 7 | 9.33 | 0.395 in. x 8 in. x 16 ft. | 2234 | 1200 | 4440 |
| 9-1/2 in. x 16 ft. Bevel Edge Lap | 7/16 in. | 6 | 210 | 8-1/2 | 11.33 | 0.395 in. x 9.500 in. x 16 ft. | 2261 | 1174 | 4405 |
| 12 in. x 16 ft. Bevel Edge Lap | 7/16 in. | 6 | 168 | 11 | 14.67 | 0.395 in. x 12 in. x 16 ft. | 2341 | 1145 | 4490 |
| 12 in. x 16 ft. Bevel Edge (Smooth) | 7/16 in. | 6 | 168 | 11 | 14.67 | 0.395 in. x 12 in. x 16 ft. | 2341 | 1145 | 4505 |
| 8 in. x 12 ft. Self-Aligning Lap | 1/2 in. | 5 | 210 | 7 | 9.33 | 0.485 in. x 8 in. x 16 ft. | 1862 | 1200 | 3945 |
| 12 in. x 16 ft. Self-Aligning Lap | 1/2 in. | 5 | 140 | 11 | 14.67 | 0.485 in. x 12 in. x 16 ft. | 1951 | 1145 | 4215 |
| 8 in. x 16 ft. Sure Lock | 1/2 in. | 5 | 210 | 7 | 9.33 | 0.485 in. x 8 in. x 16 ft. | 1862 | 1200 | 4050 |
| 12 in. x 16 ft. Sure Lock Cottage Six Lap | 1/2 in. | 5 | 140 | 11 | 14.67 | 0.485 in. x 12 in. x 16 ft. | 1951 | 1145 | 4260 |
| 12 in. x 16 ft. Sure Lock V-Rustic | 1/2 in. | 5 | 140 | 11 | 14.67 | 0.485 in. x 12 in. x 16 ft. | 1951 | 1145 | 4120 |
| 12 in. x 16 ft. TwelveFour Cottage Lap | 1/2 in. | 5 | 140 | 11 | 14.67 | 0.485 in. x 12 in. x 16 ft. | 1951 | 1145 | 3820 |
| 12 in. x 16 ft. TwelveSix Cottage Lap | 1/2 in. | 5 | 140 | 11 | 14.67 | 0.485 in. x 12 in. x 16 ft. | 1951 | 1145 | 3910 |
| 16 in. x 16 ft. 4 in. Cottage Lap | 1/2 in. | 5 | 105 | 15 | 20 | 0.485 in. x 16 in. x 16 ft. | 1995 | 1120 | 3940 |
| 16 in. x 16 ft. 5 in. Cottage Lap | 1/2 in. | 5 | 105 | 15 | 20 | 0.485 in. x 16 in. x 16 ft. | 1995 | 1120 | 4150 |
| 16 in. x 16 ft. 8 in. Cottage Lap | 1/2 in. | 5 | 105 | 15 | 20 | 0.485 in. x 16 in. x 16 ft. | 1995 | 1120 | 4150 |
| 16 in. x 16 ft. Channel Rustic | 1/2 in. | 5 | 105 | 15 | 20 | 0.485 in. x 16 in. x 16 ft. | 1995 | 1120 | 3910 |
| 11-1/2 in. x 48-13/16 in. Old Mill® Shingle Lap | 1/2 in. | 6 | 140 | 9-3/4 | 3.25 | 0.485 in. x 11.5 in. x 48.81 in. | 432 | 1238 | 1000 |
| CEDAR SHAKE LAP | | | | | | | | | |
| 10-1/2 in. x 16 ft. Self-Aligning | 1/2 in. | 5 | 140 | 9-1/2 | 12.67 | 0.485 in. x 10.5 in. x 16 ft. | 1685 | 1161 | 3700 |
| DESIGNER SHAKE LAP | | | | | | | | | |
| 9-1/2 in. x 8 ft. Round | 1/2 in. | 6 | 90 | 6-3/4 | 4.5 | 0.485 in. x 9.5 in. x 8 ft. | 385 | 1478 | 1050 |
| 9-1/2 in. x 8 ft. Fishscale | 1/2 in. | 6 | 90 | 7-1/2 | 5 | 0.485 in. x 9.5 in. x 8 ft. | 428 | 1330 | 1050 |
| 9-1/2 in. x 8 ft. Octagon | 1/2 in. | 6 | 90 | 6-3/4 | 4.5 | 0.485 in. x 9.5 in. x 8 ft. | 385 | 1478 | 1050 |
| 9-1/2 in. x 8 ft. Cove | 1/2 in. | 6 | 90 | 6-1/2 | 4.33 | 0.485 in. x 9.5 in. x 8 ft. | 370 | 1535 | 1050 |
| 9-1/2 in. x 8 ft. Diamond | 1/2 in. | 6 | 90 | 4-1/4 | 2.83 | 0.485 in. x 9.5 in. x 8 ft. | 242 | 2347 | 1050 |
| 9-1/2 in. x 8 ft. Craftsmen Staggered | 1/2 in. | 6 | 90 | 8 | 5.33 | 0.485 in. x 9.5 in. x 8 ft. | 456 | 1247 | 1050 |
| OLD MILL® SOFFIT | | | | | | | | | |
| 7/16 in. Old Mill® Soffit | 7/16 in. | 6 | 126 | 16 | 21.33 | 0.395 in. x 16 in. x 16 ft. | 2688 | 1050 | 4405 |
| 1/2 in. Old Mill® Soffit | 1/2 in. | 5 | 105 | 16 | 21.33 | 0.485 in. x 16 in. x 16 ft. | 2240 | 1050 | 4250 |

| Panel Style | Texture | Size | Pieces / Unit | Sq. ft. Coverage / Piece | Actual | Approx. Coverage Sq. ft. / Unit* | Approx. Sq. ft. Needed to Cover 1000 Sq. ft. of Wall Area* | Approx. Weight Lbs. / Unit |
|--|-----------|-----------------------------------|---------------|--------------------------|-------------------------------|----------------------------------|--|----------------------------|
| 3/4 in. Channel Groove 8 in. O.C. | Old Mill® | 7/16 in. x 48-13/16 in. x 7 ft. | 45 | 28 | 0.395 in. x 48.81 in. x 7 ft. | 1134 | 1100 | 2000 |
| 3/4 in. Channel Groove 8 in. O.C. | Old Mill® | 7/16 in. x 48-13/16 in. x 8 ft. | 45 | 32 | 0.395 in. x 48.81 in. x 8 ft. | 1296 | 1100 | 2290 |
| 3/4 in. Channel Groove 8 in. O.C. | Old Mill® | 7/16 in. x 48-13/16 in. x 9 ft.** | 45 | 36 | 0.395 in. x 48.81 in. x 9 ft. | 1458 | 1100 | 2560 |
| Reverse Board & Batten | Old Mill® | 7/16 in. x 48-13/16 in. x 8 ft.** | 45 | 32 | 0.395 in. x 48.81 in. x 8 ft. | 1296 | 1100 | 2340 |
| Sturdy Panel 8 in. O.C. (Home Depot exclusive) | Old Mill® | 7/16 in. x 48-13/16 in. x 8 ft.** | 45 | 32 | 0.395 in. x 48.81 in. x 8 ft. | 1296 | 1100 | 2300 |
| 3/8 in. Groove 8 in. O.C. | Old Mill® | 7/16 in. x 4 ft. x 8 ft. | 45 | 32 | 0.395 in. x 48.81 in. x 8 ft. | 1296 | 1100 | 2300 |
| Square Edge (Plain) | Old Mill® | 7/16 in. x 4 ft. x 8 ft. | 45 | 32 | 0.395 in. x 48 in. x 8 ft. | 1296 | 1100 | 2485 |
| Square Edge (Plain) | Smooth | 7/16 in. x 4 ft. x 8 ft. | 45 | 32 | 0.395 in. x 48 in. x 8 ft. | 1296 | 1100 | 2485 |
| 3/8 in. Striated Groove 808 8 in. O.C. | Old Mill® | 1/2 in. x 48-13/16 in. x 8 ft. | 37 | 32 | 0.485 in. x 48.81 in. x 8 ft. | 1066 | 1100 | 2270 |
| Adobe™ Panel Siding Shiplap Edge | Adobe™ | 1/2 in. x 48-13/16 in. x 8 ft. | 37 | 32 | 0.485 in. x 48.81 in. x 8 ft. | 1066 | 1100 | 2270 |

| Actual Size | Thickness | Pieces / Bundle | Pieces / Unit | Weight / Unit | Lineal ft. / Unit | Actual |
|---------------------|-----------|-----------------|---------------|---------------|-------------------|-------------------------------|
| 2-1/2 in. x 16 ft. | 3/4 in. | 12 | 360 | 3340 | 5760 | 0.75 in. x 2.5 in. x 16 ft. |
| 3-1/2 in. x 16 ft. | 3/4 in. | 8 | 240 | 3060 | 3840 | 0.75 in. x 3.5 in. x 16 ft. |
| 5-1/2 in. x 16 ft. | 3/4 in. | 8 | 160 | 3250 | 2560 | 0.75 in. x 5.5 in. x 16 ft. |
| 7-1/4 in. x 16 ft. | 3/4 in. | 4 | 120 | 3330 | 1920 | 0.75 in. x 7.25 in. x 16 ft. |
| 9-1/4 in. x 16 ft. | 3/4 in. | 4 | 100 | 3440 | 1600 | 0.75 in. x 9.25 in. x 16 ft. |
| 11-1/4 in. x 16 ft. | 3/4 in. | 4 | 80 | 3310 | 1280 | 0.75 in. x 11.25 in. x 16 ft. |

| Actual Size | Thickness | Pieces / Bundle | Pieces / Unit | Weight / Unit | Lineal ft. / Unit | Actual |
|---------------------|-----------|-----------------|---------------|---------------|-------------------|--------------------------------|
| 2-1/2 in. x 16 ft. | 1 in. | 9 | 324 | 3960 | 5184 | 0.960 in. x 2.5 in. x 16 ft. |
| 3-1/2 in. x 16 ft. | 1 in. | 6 | 216 | 3820 | 3456 | 0.960 in. x 3.5 in. x 16 ft. |
| 5-1/2 in. x 16 ft. | 1 in. | 6 | 144 | 3780 | 2304 | 0.960 in. x 4.5 in. x 16 ft. |
| 7-1/4 in. x 16 ft. | 1 in. | 3 | 108 | 3940 | 1728 | 0.960 in. x 7.25 in. x 16 ft. |
| 9-1/4 in. x 16 ft. | 1 in. | 3 | 90 | 4150 | 1440 | 0.960 in. x 9.25 in. x 16 ft. |
| 11-1/4 in. x 16 ft. | 1 in. | 3 | 72 | 4030 | 1152 | 0.960 in. x 11.25 in. x 16 ft. |

| Actual Size | Thickness | Pieces / Bundle | Pieces / Unit | Weight / Unit | Lineal ft. / Unit | Actual |
|----------------------|-----------|-----------------|---------------|---------------|-------------------|------------------------------|
| 7-1/4 in. x 16 ft.** | 3/4 in. | 4 | 120 | 3200 | 1920 | 0.75 in. x 7.25 in. x 16 ft. |

TRUWOOD NOTES

LAP SIDING

* Allows for 1 in. overlap and assumes a 5% waste factor.

PANEL SIDING AND SOFFIT

* Assumes a 10% waste factor for cutting and fitting.

All grooved panels are shiplapped on the long edges and cut oversize to provide 48 in. net coverage when applied.

Adobe panels are shiplapped on the long edges and cut oversize to provide 48 in. net coverage when applied.

** Limited availability

PLOWED FASCIA

** Old Mill® face, plowed on the back side.



Spec Sheets



TRUWOOD TRIM

TruWood® SIDING | TRIM

TRUWOOD REVERSIBLE AND NON-REVERSIBLE TRIM

Durability? Style? Versatility? With TruWood Trim, you'll get all that and more. Attractive, reliable and easy to install, TruWood Trim is ideal for band boards, batten, corner boards, cornice, door trim, fascia, frieze boards, rake boards, soffits and window trim. It offers builders and architects an unbeatable combination of Tru beauty, Tru durability and Tru ease of use. Tru perfection.

FEATURES/BENEFITS

- Quality engineered surface and core
- 30-year limited warranty
- Pre-primed for improved weatherability
- 16 ft. lengths available in 2-1/2 in. to 11-1/4 in. widths (actual)
- 1 in. (actual) is reversible with Old Mill® texture on one side and smooth on the other. Primed all four sides.
- Use for residential single-family, multi-family housing, remodeling and light commercial projects
- Easy and safe to install using normal woodworking tools. No silica dust.
- Ask us about our FSC® products (FSC®-C002971)

TREATED WITH

EcoGuard®

ZINC BORATE

- Resists mildew, rot and termite damage
- Naturally-occurring additive safe for use around children and pets

New 2-1/2 in. width now available

REVERSIBLE AND NON-REVERSIBLE TRIM

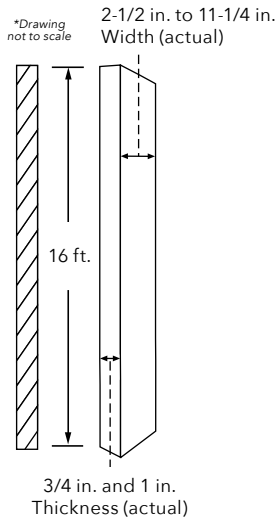

PLOWED FASCIA

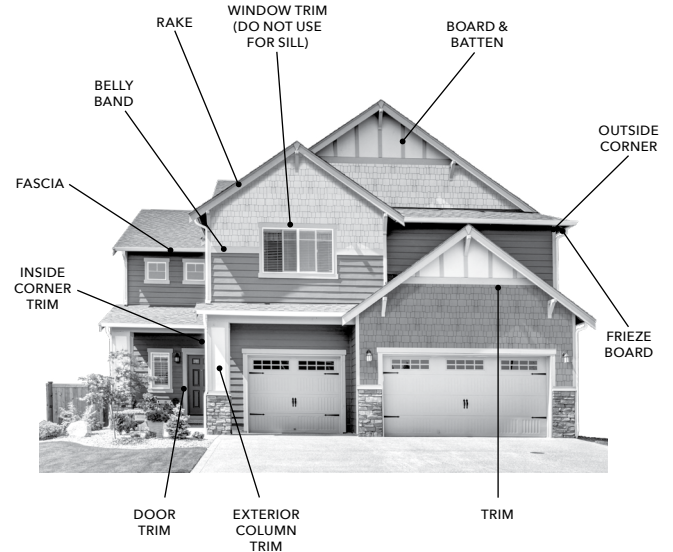
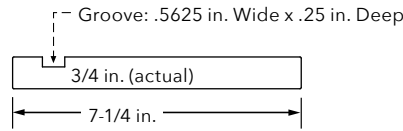

SPECIFICATIONS:

| Thickness | Pieces / Bundle | Pieces / Unit | Weight / Unit | Lineal Ft. / Unit | Actual | |
|--------------------------------|-----------------|---------------|---------------|-------------------|--------|--------------------------------|
| Non-Reversible | | | | | | |
| 3/4 in. x 2-1/2 in. x 16 ft. | 3/4 in. | 12 | 360 | 3340 | 5760 | 0.75 in. x 2.5 in. x 16 ft. |
| 3/4 in. x 3-1/2 in. x 16 ft. | 3/4 in. | 8 | 240 | 3060 | 3840 | 0.75 in. x 3.5 in. x 16 ft. |
| 3/4 in. x 5-1/2 in. x 16 ft. | 3/4 in. | 8 | 160 | 3250 | 2560 | 0.75 in. x 5.5 in. x 16 ft. |
| 3/4 in. x 7-1/4 in. x 16 ft. | 3/4 in. | 4 | 120 | 3330 | 1920 | 0.75 in. x 7.25 in. x 16 ft. |
| 3/4 in. x 9-1/4 in. x 16 ft. | 3/4 in. | 4 | 100 | 3440 | 1600 | 0.75 in. x 9.25 in. x 16 ft. |
| 3/4 in. x 11-1/4 in. x 16 ft. | 3/4 in. | 4 | 80 | 3310 | 1280 | 0.75 in. x 11.25 in. x 16 ft. |
| Reversible | | | | | | |
| 1 in. x 2-1/2 in. x 16 ft. | 1 in. | 9 | 324 | 3960 | 5184 | 0.960 in. x 2.5 in. x 16 ft. |
| 1 in. x 3-1/2 in. x 16 ft. | 1 in. | 6 | 216 | 3820 | 3456 | 0.960 in. x 3.5 in. x 16 ft. |
| 1 in. x 5-1/2 in. x 16 ft. | 1 in. | 6 | 144 | 3780 | 2304 | 0.960 in. x 4.5 in. x 16 ft. |
| 1 in. x 7-1/4 in. x 16 ft. | 1 in. | 3 | 108 | 3940 | 1728 | 0.960 in. x 7.25 in. x 16 ft. |
| 1 in. x 9-1/4 in. x 16 ft. | 1 in. | 3 | 90 | 4150 | 1440 | 0.960 in. x 9.25 in. x 16 ft. |
| 1 in. x 11-1/4 in. x 16 ft. | 1 in. | 3 | 72 | 4030 | 1152 | 0.960 in. x 11.25 in. x 16 ft. |
| Plowed Fascia | | | | | | |
| 3/4 in. x 7-1/4 in. x 16 ft.** | 3/4 in. | 4 | 120 | 3200 | 1920 | 0.75 in. x 7.25 in. x 16 ft. |

**Old Mill® face, plowed on the Smooth Side.

TruWood Siding and Trim meet the requirements of the following:

- 2024 International Building Code
- 2024 International Residential Code
- ICC ESR-2588
- ANSI A135.6-2012 (R2020)
- Wildland-Urban Interface (WUI) Approved*

*WUI APPLICATION REQUIREMENTS

- Framing must not exceed 16 in. on center.
- Minimum 5/8 in. Type-X gypsum exterior sheathing is required.

Fire rating = Class C

R Value = 0.67 (hour) (Sq. Ft.) (Fahrenheit) per BTU

1/2 in. Panel Siding = No Shear Value

CAL. PROP 65 WARNING: Use of this product may result in exposure to wood dust, known to the State of California to cause cancer.

PROPER STORAGE AND HANDLING

- Store siding flat and support on stringers to avoid sagging and contact with the ground
- Siding must be covered and protected from the elements
- Stack no more than eight units high
- Allow siding to acclimatize to local conditions prior to installation

TO FIND YOUR NEAREST DISTRIBUTOR, WARRANTY INFORMATION, INSTALLATION INSTRUCTIONS, CARE AND MAINTENANCE INSTRUCTIONS, A SIDING CALCULATOR, OR TO VIEW OUR PRODUCTS ON SAMPLE HOMES USING OUR VISUALIZER TOOL, HEAD TO [TruWoodSiding.com](https://www.TruWoodSiding.com). CAN'T FIND WHAT YOU NEED? **800.417.3674**



TruWood[®]
SIDING | TRIM

TRUWOOD COTTAGE LAP® SIDING

Looking for Old World charm without the Old World hassle and costs? Our six Cottage Lap® profiles offer Tru beauty and Tru labor savings. Our Channel Rustic™ Lap Siding provides heritage style and enduring quality with distinctive cedar channel groove siding. Other 16 in. profiles include the 4 in., 5 in. and 8 in. Cottage Laps. The TwelveFour and TwelveSix Cottage Lap patterns deliver the same unique features in a 12 in. wide board. The choice of our self-aligning feature for all boards makes installation faster and easier, saving you time and money. Talk about a Tru advantage.

FEATURES/BENEFITS

- Quality engineered surface and core
- 30-year limited warranty
- Pre-primed for improved weatherability
- 16 ft. lengths
- Self-aligning feature for ease of installation
- Matching TruWood Trim
- Installs 25-40% faster than cement or vinyl sidings
- Use for residential single-family, multi-family housing, remodeling and light commercial projects
- Easy and safe to install using normal woodworking tools. No silica dust.
- Ask us about our FSC® products (FSC®-C002971)

TREATED WITH

EcoGuard[®]

ZINC BORATE

- Resists mildew, rot and termite damage
- Naturally-occurring additive safe for use around children and pets

4 in. COTTAGE LAP
7/8 in. GROOVE
1/2 in. LAP SIDING

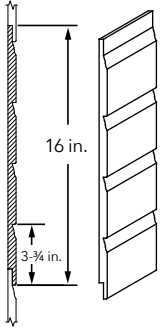

5 in. COTTAGE LAP
7/8 in. GROOVE
1/2 in. LAP SIDING

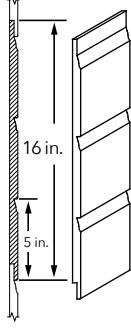

8 in. COTTAGE LAP
7/8 in. GROOVE
1/2 in. LAP SIDING

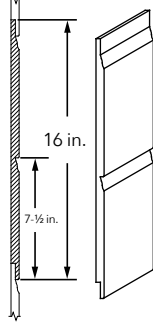

CHANNEL RUSTIC
1 in. GROOVE
1/2 in. LAP SIDING

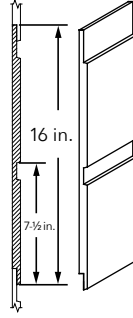

TWELVEFOUR COTTAGE LAP
7/8 in. GROOVE
1/2 in. LAP SIDING

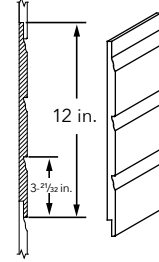

TWELVESIX COTTAGE LAP
7/8 in. GROOVE
1/2 in. LAP SIDING

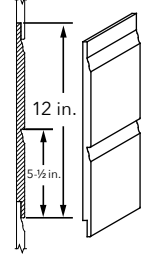

SPECIFICATIONS:

| Lap Size | Pc./ Bundle | Pc./ Unit | Maximum Exposure in inches | Sq. Ft. Coverage Per Piece | Approx Coverage Sq. Ft./ Unit | Sq. Ft. Needed To Cover 1,000 Sq. Ft. of Wall Area | Approx. Weight Lbs./Unit |
|---------------------------|-------------|-----------|----------------------------|----------------------------|-------------------------------|--|--------------------------|
| 1/2 in. x 12 in. x 16 ft. | 5 | 140 | 11 | 14.67 | 1951 | 1145 | 3820 |
| 1/2 in. x 12 in. x 16 ft. | 5 | 140 | 11 | 14.67 | 1951 | 1145 | 3910 |
| 1/2 in. x 16 in. x 16 ft. | 5 | 105 | 15 | 20 | 1995 | 1120 | 3940 |
| 1/2 in. x 16 in. x 16 ft. | 5 | 105 | 15 | 20 | 1995 | 1120 | 4150 |
| 1/2 in. x 16 in. x 16 ft. | 5 | 105 | 15 | 20 | 1995 | 1120 | 4150 |
| 1/2 in. x 16 in. x 16 ft. | 5 | 105 | 15 | 20 | 1995 | 1120 | 3910 |

*Allows for a 1 in. overlap and assumes a 5% waste factor.

Selection

| Lap Style | Profile | Surface Texture |
|---------------------------|-------------------|-----------------|
| 1/2 in. x 12 in. x 16 ft. | TwelveFour | Old Mill® |
| 1/2 in. x 12 in. x 16 ft. | TwelveSix | Old Mill® |
| 1/2 in. x 16 in. x 16 ft. | 4 in. Cottage Lap | Old Mill® |
| 1/2 in. x 16 in. x 16 ft. | 5 in. Cottage Lap | Old Mill® |
| 1/2 in. x 16 in. x 16 ft. | 8 in. Cottage Lap | Old Mill® |
| 1/2 in. x 16 in. x 16 ft. | Channel Rustic | Old Mill® |

TruWood Siding and Trim meet the requirements of the following:

2024 International Building Code
2024 International Residential Code
ICC ESR-2588
ANSI A135.6-2012 (R2020)
Wildland-Urban Interface (WUI) Approved*

*WUI APPLICATION REQUIREMENTS

- Framing must not exceed 16 in. on center.
- Minimum 5/8 in. Type-X gypsum exterior sheathing is required.

Fire rating = Class C

R Value = 0.67 (hour) (Sq. Ft.) (Fahrenheit) per BTU

1/2 in. Panel Siding = No Shear Value

CAL. PROP 65 WARNING: Use of this product may result in exposure to wood dust, known to the State of California to cause cancer.

PROPER STORAGE AND HANDLING

- Store siding flat and support on stringers to avoid sagging and contact with the ground
- Siding must be covered and protected from the elements
- Stack no more than eight units high
- Allow siding to acclimatize to local conditions prior to installation

TO FIND YOUR NEAREST DISTRIBUTOR, WARRANTY INFORMATION, INSTALLATION INSTRUCTIONS, CARE AND MAINTENANCE INSTRUCTIONS, A SIDING CALCULATOR, OR TO VIEW OUR PRODUCTS ON SAMPLE HOMES USING OUR VISUALIZER TOOL, HEAD TO [TruWoodSiding.com](https://www.TruWoodSiding.com). CAN'T FIND WHAT YOU NEED? **800.417.3674**





TruWood[®]
SIDING | TRIM

TRUWOOD SELF-ALIGNING LAP SIDING

TruWood 1/2 in. Lap Siding's self-aligning feature creates Tru ease of installation, Tru time reduction and Tru labor savings. TruWood Siding combines a competitive price point and high quality to set a new industry standard for value. With expert craftsmanship and proven performance, TruWood Siding is the Tru choice for today's discerning builders.

FEATURES/BENEFITS

- Quality engineered surface and core
- 30-year limited warranty
- Pre-primed for improved weatherability
- 16 ft. lengths
- Matching TruWood Trim
- Installs 25-40% faster than cement or vinyl sidings
- Use for residential single-family, multi-family housing, remodeling and light commercial projects
- Easy and safe to install using normal woodworking tools. No silica dust.
- Ask us about our FSC[®] products (FSC[®]-C002971)

TREATED WITH

EcoGuard[®]

ZINC BORATE

- Resists mildew, rot and termite damage
- Naturally-occurring additive safe for use around children and pets

**SELF-ALIGNING
1/2 in. LAP SIDING**

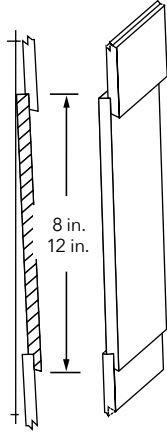

SPECIFICATIONS:

| Lap Size | Pc./ Bundle | Pc./ Unit | Maximum Exposure in inches | Sq. Ft. Coverage Per Piece | Approx Coverage Sq. Ft./ Unit | Sq. Ft. Needed To Cover 1,000 Sq. Ft. of Wall Area | Approx. Weight Lbs./Unit |
|---------------------------|-------------|-----------|----------------------------|----------------------------|-------------------------------|--|--------------------------|
| 1/2 in. x 8 in. x 16 ft. | 5 | 210 | 7 | 9.33 | 1862 | 1200 | 3945 |
| 1/2 in. x 12 in. x 16 ft. | 5 | 140 | 11 | 14.67 | 1951 | 1145 | 4215 |

*Allows for a 1 in. overlap and assumes a 5% waste factor.

Selection

| Lap Size | Surface Texture |
|---------------------------|-----------------|
| 1/2 in. x 8 in. x 16 ft. | Old Mill® |
| 1/2 in. x 12 in. x 16 ft. | Old Mill® |

TruWood Siding and Trim meet the requirements of the following:

- 2024 International Building Code
- 2024 International Residential Code
- ICC ESR-2588
- ANSI A135.6-2012 (R2020)
- Wildland-Urban Interface (WUI) Approved*

***WUI APPLICATION REQUIREMENTS**

- Framing must not exceed 16 in. on center.
- Minimum 5/8 in. Type-X gypsum exterior sheathing is required.

Fire rating = Class C

R Value = 0.67 (hour) (Sq. Ft.) (Fahrenheit) per BTU

1/2 in. Panel Siding = No Shear Value

CAL. PROP 65 WARNING: Use of this product may result in exposure to wood dust, known to the State of California to cause cancer.

PROPER STORAGE AND HANDLING

- Store siding flat and support on stringers to avoid sagging and contact with the ground
- Siding must be covered and protected from the elements
- Stack no more than eight units high
- Allow siding to acclimatize to local conditions prior to installation

TO FIND YOUR NEAREST DISTRIBUTOR, WARRANTY INFORMATION, INSTALLATION INSTRUCTIONS, CARE AND MAINTENANCE INSTRUCTIONS, A SIDING CALCULATOR, OR TO VIEW OUR PRODUCTS ON SAMPLE HOMES USING OUR VISUALIZER TOOL, HEAD TO **TruWoodSiding.com**. CAN'T FIND WHAT YOU NEED? **800.417.3674**





TruWood[®]
SIDING | TRIM

TRUWOOD CEDAR SHAKE LAP SIDING

When only the look of cedar will do, TruWood Cedar Shake Lap Siding offers an alternative that's beautiful, rugged and cost-effective. You won't find any checks, cracks or surface variations in our TruWood Cedar Shake 1/2 in. Lap Siding. What you will find: the distinctive look of hand-split cedar shakes with a beautiful, finished appearance that lasts. Our Cedar Shake Lap Siding offers Tru character, Tru wood appeal and smooth, uniform paint application. No defects, hassles or high costs. Just Tru beauty.

FEATURES/BENEFITS

- Quality engineered surface and core
- 30-year limited warranty
- Pre-primed for improved weatherability
- 16 ft. lengths
- Self-aligning feature for ease of installation
- Matching TruWood Trim
- Installs 25-40% faster than cement or vinyl sidings
- Use for residential single-family, multi-family housing, remodeling and light commercial projects
- Easy and safe to install using normal woodworking tools. No silica dust.
- Ask us about our FSC[®] products (FSC[®]-C002971)

TREATED WITH

EcoGuard[®]

ZINC BORATE

- Resists mildew, rot and termite damage
- Naturally-occurring additive safe for use around children and pets

**SELF-ALIGNING
CEDAR SHAKE
1/2 in. LAP SIDING**

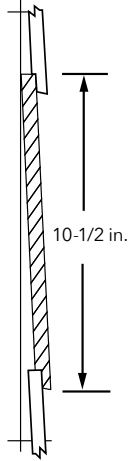

SPECIFICATIONS:

| Lap Size | Pc./ Bundle | Pc./ Unit | Maximum Exposure in inches | Sq. Ft. Coverage Per Piece | Approx Coverage Sq. Ft./ Unit | Sq. Ft. Needed To Cover 1,000 Sq. Ft. of Wall Area | Approx. Weight Lbs./Unit |
|-------------------------------|----------------|--------------|----------------------------------|----------------------------------|--|---|--------------------------------|
| 1/2 in. x 10-1/2 in. x 16 ft. | 5 | 140 | 9-1/2 | 12.67 | 1685 | 1161 | 3700 |

*Allows for a 1 in overlap and assumes a 5% waste factor.

TruWood Siding and Trim meet the requirements of the following:

- 2024 International Building Code
- 2024 International Residential Code
- ICC ESR-2588
- ANSI A135.6-2012 (R2020)
- Wildland-Urban Interface (WUI) Approved*

***WUI APPLICATION REQUIREMENTS**

- Framing must not exceed 16 in. on center.
- Minimum 5/8 in. Type-X gypsum exterior sheathing is required.

Fire rating = Class C

R Value = 0.67 (hour) (Sq. Ft.) (Fahrenheit) per BTU

1/2 in. Panel Siding = No Shear Value

CAL. PROP 65 WARNING: Use of this product may result in exposure to wood dust, known to the State of California to cause cancer.

PROPER STORAGE AND HANDLING

- Store siding flat and support on stringers to avoid sagging and contact with the ground
- Siding must be covered and protected from the elements
- Stack no more than eight units high
- Allow siding to acclimatize to local conditions prior to installation

TO FIND YOUR NEAREST DISTRIBUTOR, WARRANTY INFORMATION, INSTALLATION INSTRUCTIONS, CARE AND MAINTENANCE INSTRUCTIONS, A SIDING CALCULATOR, OR TO VIEW OUR PRODUCTS ON SAMPLE HOMES USING OUR VISUALIZER TOOL, HEAD TO **TruWoodSiding.com**. CAN'T FIND WHAT YOU NEED? **800.417.3674**





12 in. SURE LOCK V-RUSTIC LAP

8 in. SURE LOCK LAP

SURE LOCK SIX COTTAGE LAP

SURE LOCK™ LAP SIDING

SURE LOCK™ LAP SIDING WITH CONCEALED NAILING SYSTEM

TruWood Sure Lock™ 1/2 in. Lap Siding does more than securely lock in each piece of siding, it also locks in Tru beauty. Sure Lock uses a hidden nail design that allows for flexible and easy application, and features our Old Mill® textured surface for the look of cedar without the defects or high cost. And now, you can also opt for our new 12 in. V-Rustic siding for the lasting curb appeal of mid-century modern style. No matter which you choose, you'll always get quality and character that lasts.

FEATURES/BENEFITS

- Sure Lock profile assures straight, level installation
- Quality engineered surface and core
- 30-year limited warranty
- Pre-primed for improved weatherability
- 16 ft. lengths
- Matching TruWood Trim
- Installs 25-40% faster than cement or vinyl sidings
- Use for residential single-family, multi-family housing, remodeling and light commercial projects
- Easy and safe to install using normal woodworking tools. No silica dust.
- Ask us about our FSC® products (FSC®-C002971)

New V-Rustic style now available

8 in. SURE LOCK
1/2 in. LAP SIDING

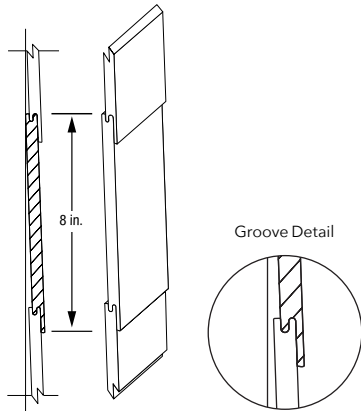

SURE LOCK SIX COTTAGE LAP
7/8 in. GROOVE
1/2 in. LAP SIDING

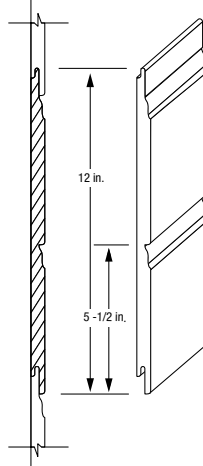

12 in. SURE LOCK V-RUSTIC
3/8 in. GROOVE
1/2 in. LAP SIDING

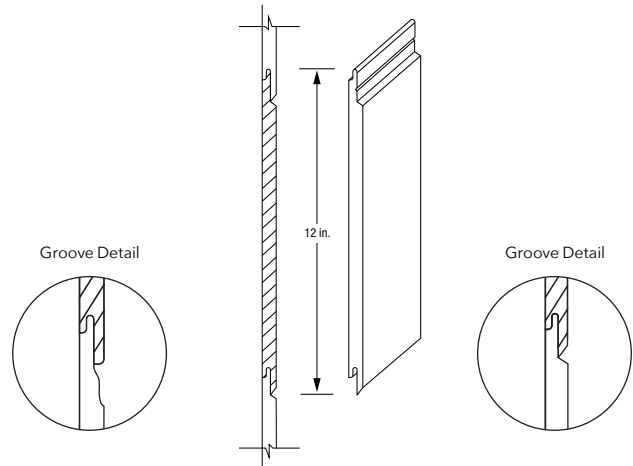

SPECIFICATIONS:

8 in. Sure Lock™ Lap Siding

| Lap Size | Pc./ Bundle | Pc./ Unit | Maximum Exposure in inches | Sq. Ft. Coverage Per Piece | Approx Coverage Sq. Ft./ Unit | Sq. Ft. Needed To Cover 1,000 Sq. Ft. of Wall Area | Approx. Weight Lbs./Unit |
|--------------------------|-------------|-----------|----------------------------|----------------------------|-------------------------------|--|--------------------------|
| 1/2 in. x 8 in. x 16 ft. | 5 | 210 | 7 | 9.33 | 1862 | 1200 | 4050 |

Sure Lock Six Cottage Lap® Siding

| Lap Size | Pc./ Bundle | Pc./ Unit | Maximum Exposure in inches | Sq. Ft. Coverage Per Piece | Approx Coverage Sq. Ft./ Unit | Sq. Ft. Needed To Cover 1,000 Sq. Ft. of Wall Area | Approx. Weight Lbs./Unit |
|---------------------------|-------------|-----------|----------------------------|----------------------------|-------------------------------|--|--------------------------|
| 1/2 in. x 12 in. x 16 ft. | 5 | 140 | 11 | 14.67 | 1951 | 1145 | 4260 |

12 in. Sure Lock V-Rustic Lap Siding

| Lap Size | Pc./ Bundle | Pc./ Unit | Maximum Exposure in inches | Sq. Ft. Coverage Per Piece | Approx Coverage Sq. Ft./ Unit | Sq. Ft. Needed To Cover 1,000 Sq. Ft. of Wall Area | Approx. Weight Lbs./Unit |
|---------------------------|-------------|-----------|----------------------------|----------------------------|-------------------------------|--|--------------------------|
| 1/2 in. x 12 in. x 16 ft. | 5 | 140 | 11 | 14.67 | 1951 | 1145 | 4120 |

Selection

| Lap Style | Size | Surface Texture |
|-------------------------------|---------------------------|-----------------|
| 8 in. Sure Lock Lap | 1/2 in. x 8 in. x 16 ft. | Old Mill® |
| Sure Lock Six Cottage Lap | 1/2 in. x 12 in. x 16 ft. | Old Mill® |
| 12 in. Sure Lock V-Rustic Lap | 1/2 in. x 12 in. x 16 ft. | Old Mill® |

*Allows for a 1 in. overlap and assumes a 5% waste factor.

TruWood Siding and Trim meet the requirements of the following:

2024 International Building Code
2024 International Residential Code
ICC ESR-2588
ANSI A135.6-2012 (R2020)
Wildland-Urban Interface (WUI) Approved*

*WUI APPLICATION REQUIREMENTS

- Framing must not exceed 16 in. on center.
- Minimum 5/8 in. Type-X gypsum exterior sheathing is required.

Fire rating = Class C

R Value = 0.67 (hour) (Sq. Ft.) (Fahrenheit) per BTU

1/2 in. Panel Siding = No Shear Value

CAL. PROP 65 WARNING: Use of this product may result in exposure to wood dust, known to the State of California to cause cancer.

PROPER STORAGE AND HANDLING

- Store siding flat and support on stringers to avoid sagging and contact with the ground
- Siding must be covered and protected from the elements
- Stack no more than eight units high
- Allow siding to acclimatize to local conditions prior to installation

TO FIND YOUR NEAREST DISTRIBUTOR, WARRANTY INFORMATION, INSTALLATION INSTRUCTIONS, CARE AND MAINTENANCE INSTRUCTIONS, A SIDING CALCULATOR, OR TO VIEW OUR PRODUCTS ON SAMPLE HOMES USING OUR VISUALIZER TOOL, HEAD TO **TruWoodSiding.com**. CAN'T FIND WHAT YOU NEED? **800.417.3674**





TruWood[®]
SIDING | TRIM

TRUWOOD DESIGNER SHAKE® LAP SIDING

Your house is more than just a pretty face. With TruWood, you can give it a Tru personality. TruWood Designer Shake® 1/2 in. Lap Siding offers irresistible style, authentic real wood appearance and numerous design options at significant savings over cedar. Available in 8 ft. lengths, TruWood Designer Shake is also much easier to install than the traditional “one shingle at a time” method, for ease and convenience. Add a distinctive accent. Create architectural appeal and long-lasting quality. Make your house a home with Tru appeal.

FEATURES/BENEFITS

- Quality engineered surface and core
- 30-year limited warranty
- Pre-primed for improved weatherability
- Easy to handle 8 ft. lengths
- Matching TruWood Trim
- Installs 25-40% faster than cement or vinyl sidings
- Use for residential single-family, multi-family housing, remodeling and light commercial projects
- Easy and safe to install using normal woodworking tools. No silica dust.
- Ask us about our FSC® products (FSC®-C002971)

TREATED WITH

EcoGuard[®]

ZINC BORATE

- Resists mildew, rot and termite damage
- Naturally-occurring additive safe for use around children and pets

DESIGNER SHAKE CRAFTSMEN STAGGERED
1/2 in. LAP SIDING

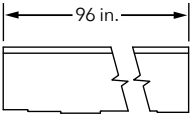

DESIGNER SHAKE ROUND
1/2 in. LAP SIDING

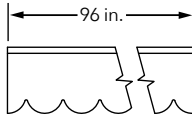

DESIGNER SHAKE COVE
1/2 in. LAP SIDING

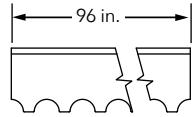

DESIGNER SHAKE FISHSCALE
1/2 in. LAP SIDING

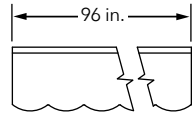

DESIGNER SHAKE OCTAGON
1/2 in. LAP SIDING

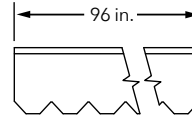

DESIGNER SHAKE DIAMOND
1/2 in. LAP SIDING

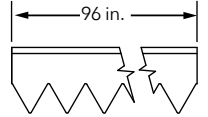

SPECIFICATIONS:

| Lap Size | Pc./ Unit | Maximum Exposure in inches | Sq. Ft. Coverage Per Piece | Approx Coverage Sq. Ft./ Unit | Sq. Ft. Needed To Cover 1,000 Sq. Ft. of Wall Area | Approx. Weight Lbs./Unit |
|---|-----------|----------------------------|----------------------------|-------------------------------|--|--------------------------|
| ROUND 1/2 in. x 9-1/2 in. x 8 ft. | 90 | 6-3/4 | 4.5 | 385 | 1478 | 1050 |
| FISHSCALE 1/2 in. x 9-1/2 in. x 8 ft. | 90 | 7-1/2 | 5 | 428 | 1330 | 1050 |
| OCTAGON 1/2 in. x 9-1/2 in. x 8 ft. | 90 | 6-3/4 | 4.5 | 385 | 1478 | 1050 |
| COVE 1/2 in. x 9-1/2 in. x 8 ft. | 90 | 6-1/2 | 4.33 | 370 | 1535 | 1050 |
| DIAMOND 1/2 in. x 9-1/2 in. x 8 ft. | 90 | 4-1/4 | 2.83 | 242 | 2437 | 1050 |
| CRAFTSMEN STAGGERED 1/2 in. x 9-1/2 in. x 8 ft. | 90 | 8 | 5.33 | 456 | 1247 | 1050 |

TruWood Siding and Trim meet the requirements of the following:

2024 International Building Code
 2024 International Residential Code
 ICC ESR-2588
 ANSI A135.6-2012 (R2020)
 Wildland-Urban Interface (WUI) Approved*

*WUI APPLICATION REQUIREMENTS

- Framing must not exceed 16 in. on center.
- Minimum 5/8 in. Type-X gypsum exterior sheathing is required.

Fire rating = Class C

R Value = 0.67 (hour) (Sq. Ft.) (Fahrenheit) per BTU

1/2 in. Panel Siding = No Shear Value

CAL. PROP 65 WARNING: Use of this product may result in exposure to wood dust, known to the State of California to cause cancer.

PROPER STORAGE AND HANDLING

- Store siding flat and support on stringers to avoid sagging and contact with the ground
- Siding must be covered and protected from the elements
- Stack no more than eight units high
- Allow siding to acclimatize to local conditions prior to installation

TO FIND YOUR NEAREST DISTRIBUTOR, WARRANTY INFORMATION, INSTALLATION INSTRUCTIONS, CARE AND MAINTENANCE INSTRUCTIONS, A SIDING CALCULATOR, OR TO VIEW OUR PRODUCTS ON SAMPLE HOMES USING OUR VISUALIZER TOOL, HEAD TO **TruWoodSiding.com**. CAN'T FIND WHAT YOU NEED? **800.417.3674**





TruWood®

SIDING | TRIM

TRUWOOD OLD MILL® SHINGLE LAP SIDING

Architectural charm and the rich appearance of split shingle without the cost? It's Tru. With TruWood Old Mill® Shingle Lap Siding, you'll experience Tru quality, Tru style and Tru value. Less expensive and more durable than cedar, TruWood Old Mill Shingle Siding offers architectural accents without the typical number of culls or odd lengths. The staggered edge line of split shingle provides a warm, natural appearance that resists whatever Mother Nature throws at it. With shiplap edges that are easier to install, even your labor costs are lower. Truly amazing.

FEATURES/BENEFITS

- Quality engineered surface and core
- 30-year limited warranty
- Pre-primed for improved weatherability
- Easy to handle 4 ft. lengths
- Matching TruWood Trim
- Versatile piece allows for staggered or straight-edge application
- Installs 25-40% faster than cement or vinyl sidings
- Use for residential single-family, multi-family housing, remodeling and light commercial projects
- Easy and safe to install using normal woodworking tools. No silica dust.
- Ask us about our FSC® products (FSC®-C002971)

TREATED WITH

EcoGuard®

ZINC BORATE

- Resists mildew, rot and termite damage
- Naturally-occurring additive safe for use around children and pets

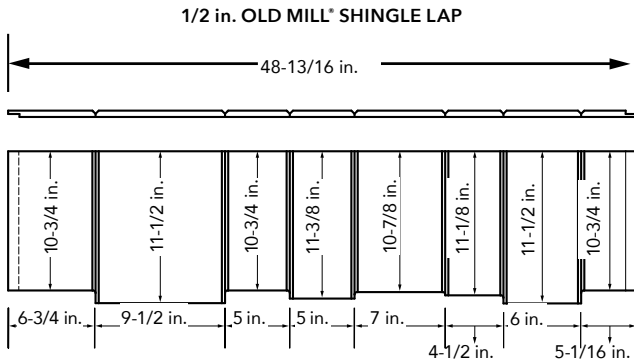

TruWood Old Mill® Shingle Lap Siding goes up fast and easy. It requires no special tools for installation and it comes in easy to handle 4 ft. lengths and a convenient shiplap edge.

SPECIFICATIONS:

| Lap Size | Pc./ Unit | Maximum Exposure in inches | Sq. Ft. Coverage Per Piece | Approx Coverage Sq. Ft./ Unit | Sq. Ft. Needed To Cover 1,000 Sq. Ft. of Wall Area | Approx. Weight Lbs./Unit |
|-------------------------------------|-----------|----------------------------|----------------------------|-------------------------------|--|--------------------------|
| 1/2 in. x 11-1/2 in. x 48-13/16 in. | 140 | 9-3/4 | 3.25 | 432 | 1238 | 1000 |

*Allows for a 1.75 in. overlap and assumes a 5% waste factor.

TruWood Siding and Trim meet the requirements of the following:

2024 International Building Code
 2024 International Residential Code
 ICC ESR-2588
 ANSI A135.6-2012 (R2020)
 Wildland-Urban Interface (WUI) Approved*

*WUI APPLICATION REQUIREMENTS

- Framing must not exceed 16 in. on center.
- Minimum 5/8 in. Type-X gypsum exterior sheathing is required.

Fire rating = Class C

R Value = 0.67 (hour) (Sq. Ft.) (Fahrenheit) per BTU

1/2 in. Panel Siding = No Shear Value

CAL. PROP 65 WARNING: Use of this product may result in exposure to wood dust, known to the State of California to cause cancer.

PROPER STORAGE AND HANDLING

- Store siding flat and support on stringers to avoid sagging and contact with the ground
- Siding must be covered and protected from the elements
- Stack no more than eight units high
- Allow siding to acclimatize to local conditions prior to installation

TO FIND YOUR NEAREST DISTRIBUTOR, WARRANTY INFORMATION, INSTALLATION INSTRUCTIONS, CARE AND MAINTENANCE INSTRUCTIONS, A SIDING CALCULATOR, OR TO VIEW OUR PRODUCTS ON SAMPLE HOMES USING OUR VISUALIZER TOOL, HEAD TO **TruWoodSiding.com**. CAN'T FIND WHAT YOU NEED? **800.417.3674**





TruWood[®]
SIDING | TRIM

TRUWOOD ADOBE™ PANEL SIDING

Who says you can't have it all? TruWood Adobe™ 1/2 in. Panel Siding gives you Tru stucco texture, right down to the finisher's trowel marks. Engineered to be more damage-resistant than today's stucco, TruWood Adobe 1/2 in. Panel Siding offers easy installation with a shiplap edge and smooth, uniform paint application. All the benefits without the cost of masonry or the inconvenience of a lengthy curing time. The result: Tru Tudor elegance. Tru in architectural luxury. A Truly unforgettable first impression that lasts and lasts.

FEATURES/BENEFITS

- Quality engineered surface and core
- 30-year limited warranty
- Pre-primed for improved weatherability
- 4 ft. x 8 ft. panels for optimal versatility
- Matching TruWood Trim
- Installs 25-40% faster than cement or vinyl sidings
- Use for residential single-family, multi-family housing, remodeling and light commercial projects
- Easy and safe to install using normal woodworking tools. No silica dust.
- Ask us about our FSC® products (FSC®-C002971)

TREATED WITH

EcoGuard[®]

ZINC BORATE

- Resists mildew, rot and termite damage
- Naturally-occurring additive safe for use around children and pets

1/2 in. ADOBE™ PANEL SIDING SHIPLAP EDGE

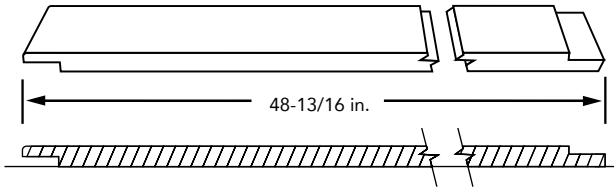

SPECIFICATIONS:

| Panel Size | Pc./ Unit | Sq. Ft. Coverage Per Piece | Approx Coverage Sq. Ft./ Unit | Approx. Sq. Ft. Needed To Cover 1,000 Sq. Ft. of Wall Area | Approx. Weight Lbs./Unit |
|--------------------------------|-----------|----------------------------|-------------------------------|--|--------------------------|
| 1/2 in. x 48-13/16 in. x 8 ft. | 37 | 32 | 1066 | 1100 | 2270 |

* Assumes 10% waste factor for cutting and fitting.
Adobe panels are shiplapped on the long edges and cut oversize to provide 48 in. net coverage when applied.

TruWood Siding and Trim meet the requirements of the following:

2024 International Building Code
2024 International Residential Code
ICC ESR-2588
ANSI A135.6-2012 (R2020)
Wildland-Urban Interface (WUI) Approved*

*WUI APPLICATION REQUIREMENTS

- Framing must not exceed 16 in. on center.
- Minimum 5/8 in. Type-X gypsum exterior sheathing is required.

Fire rating = Class C

R Value = 0.67 (hour) (Sq. Ft.) (Fahrenheit) per BTU

1/2 in. Panel Siding = No Shear Value

CAL. PROP 65 WARNING: Use of this product may result in exposure to wood dust, known to the State of California to cause cancer.

PROPER STORAGE AND HANDLING

- Store siding flat and support on stringers to avoid sagging and contact with the ground
- Siding must be covered and protected from the elements
- Stack no more than eight units high
- Allow siding to acclimatize to local conditions prior to installation

TO FIND YOUR NEAREST DISTRIBUTOR, WARRANTY INFORMATION, INSTALLATION INSTRUCTIONS, CARE AND MAINTENANCE INSTRUCTIONS, A SIDING CALCULATOR, OR TO VIEW OUR PRODUCTS ON SAMPLE HOMES USING OUR VISUALIZER TOOL, HEAD TO **TruWoodSiding.com**. CAN'T FIND WHAT YOU NEED? **800.417.3674**





TruWood® SIDING | TRIM

TRUWOOD PANEL SIDING & SOFFIT

TruWood 7/16 in. and 1/2 in. Panel Sidings are engineered to provide Tru curb appeal. With a highly paintable, textured surface, TruWood Panel Siding provides the look of cedar without checks or cracks that can detract from the appearance of your project. TruWood Siding combines competitive prices and high quality to set a new industry standard for value. Expert craftsmanship and proven performance make TruWood Siding an excellent choice for today's quality and value conscious builders.

FEATURES/BENEFITS

- Quality engineered surface and core
- 30-year limited warranty
- Pre-primed for improved weatherability
- Matching TruWood Trim
- Installs 25-40% faster than cement or vinyl sidings
- Use for residential single-family, multi-family housing, remodeling and light commercial projects
- Easy and safe to install using normal woodworking tools. No silica dust.
- Ask us about our FSC® products (FSC®-C002971)

TREATED WITH

EcoGuard®

ZINC BORATE

- Resists mildew, rot and termite damage
- Naturally-occurring additive safe for use around children and pets

1/2 IN. OLD MILL® 808 STRIATED GROOVE
7/16 IN. 3/8 IN. GROOVE
7/16 IN. STURDY PANEL

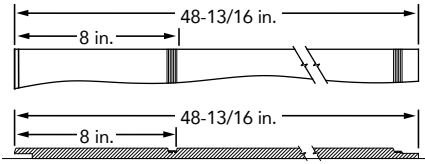

7/16 in. OLD MILL® 8 in. O.C. CHANNEL GROOVE - 3/4 in. GROOVE
(also available in 4 ft. x 7 ft. and 4 ft. x 9 ft. panels)

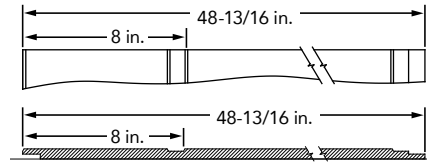

7/16 in. OLD MILL® 12 in. REVERSE BOARD AND BATTEN - 1-3/16 in. GROOVE

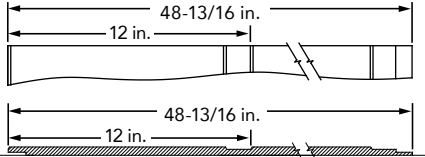

7/16 in. OLD MILL® SQUARE EDGE
7/16 in. SMOOTH SQUARE EDGE

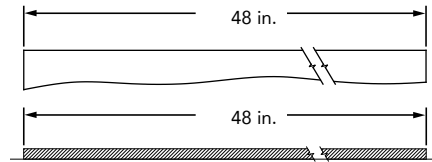

SPECIFICATIONS:

| Panel Size | Pc./ Unit | Sq. Ft. Coverage Per Piece | Approx. Coverage Sq. Ft./ Unit | Sq. Ft. Needed To Cover 1,000 Sq. Ft. of Wall Area | Approx. Weight Lbs./Unit |
|-----------------------------------|-----------|----------------------------|--------------------------------|--|--------------------------|
| 7/16 in. x 48-13/16 in. x 7 ft. | 45 | 28 | 1134 | 1100 | 2050 |
| 7/16 in. x 48-13/16 in. x 8 ft. | 45 | 32 | 1296 | 1100 | 2400 |
| 7/16 in. x 48-13/16 in. x 9 ft.** | 45 | 36 | 1458 | 1100 | 2560 |
| 1/2 in. x 48-13/16 in. x 8 ft. | 37 | 32 | 1066 | 1100 | 2270 |

* Assumes 10% waste factor for cutting and fitting. All grooved panels are shiplapped on the long edges and cut oversize to provide 48 in. net coverage when applied.

**Limited availability

Selection

| Panel Style | Sizes | Surface Texture |
|--|-----------------------------------|--------------------|
| Sturdy Panel 3/8 in. Groove 8 in. O.C. | 7/16 in. x 48-13/16 in. x 8 ft. | Old Mill® |
| 3/4 Channel Groove 8 in. O.C. | 7/16 in. x 48-13/16 in. x 7 ft. | Old Mill® |
| 3/4 Channel Groove 8 in. O.C. | 7/16 in. x 48-13/16 in. x 8 ft. | Old Mill® |
| 3/4 Channel Groove 8 in. O.C. | 7/16 in. x 48-13/16 in. x 9 ft.** | Old Mill® |
| Reverse Board & Batten 12 in. O.C. | 7/16 in. x 48-13/16 in. x 8 ft. | Old Mill® |
| 3/8 in. Striated Groove 808 8 in. O.C. | 1/2 in. x 48-13/16 in. x 8 ft. | Old Mill® |
| Square Edge (Plain) | 7/16 in. x 4 ft. x 8 ft. | Old Mill® & Smooth |
| Adobe™ Panel Siding Shiplap Edge | 1/2 in. x 48-13/16 in. x 8 ft. | Adobe™ |

Old Mill® Soffit

| Soffit Size | Pc./ Bundle | Pc./ Unit | Maximum Exposure in inches | Sq. Ft. Coverage Per Piece | Actual | Approx. Coverage Sq. Ft./ Unit | Sq. Ft. Needed To Cover 1,000 Sq. Ft. of Wall Area | Approx. Weight Lbs./Unit |
|-------------|-------------|-----------|----------------------------|----------------------------|----------------------------|--------------------------------|--|--------------------------|
| 7/16 in. | 6 | 126 | 16 | 21.33 | .395 in. x 16 in. x 16 ft. | 2688 | 1050 | 4405 |
| 1/2 in. | 5 | 105 | 16 | 21.33 | .485 in. x 16 in. x 16 ft. | 2240 | 1050 | 4250 |

TruWood Siding and Trim meet the requirements of the following:

- 2024 International Building Code
- 2024 International Residential Code
- ICC ESR-2588
- ANSI A135.6-2012 (R2020)
- Wildland-Urban Interface (WUI) Approved*

*WUI APPLICATION REQUIREMENTS

- Framing must not exceed 16 in. on center.
- Minimum 5/8 in. Type-X gypsum exterior sheathing is required.

Fire rating = Class C

R Value = 0.67 (hour) (Sq. Ft.) (Fahrenheit) per BTU

1/2 in. Panel Siding = No Shear Value

CAL. PROP 65 WARNING: Use of this product may result in exposure to wood dust, known to the State of California to cause cancer.

PROPER STORAGE AND HANDLING

- Store siding flat and support on stringers to avoid sagging and contact with the ground
- Siding must be covered and protected from the elements
- Stack no more than eight units high
- Allow siding to acclimatize to local conditions prior to installation

TO FIND YOUR NEAREST DISTRIBUTOR, WARRANTY INFORMATION, INSTALLATION INSTRUCTIONS, CARE AND MAINTENANCE INSTRUCTIONS, A SIDING CALCULATOR, OR TO VIEW OUR PRODUCTS ON SAMPLE HOMES USING OUR VISUALIZER TOOL, HEAD TO [TruWoodSiding.com](https://www.TruWoodSiding.com). CAN'T FIND WHAT YOU NEED? **800.417.3674**





TruWood[®]
SIDING | TRIM

TRUWOOD ADOBE™ PANEL SIDING

Who says you can't have it all? TruWood Adobe™ 1/2 in. Panel Siding gives you Tru stucco texture, right down to the finisher's trowel marks. Engineered to be more damage-resistant than today's stucco, TruWood Adobe 1/2 in. Panel Siding offers easy installation with a shiplap edge and smooth, uniform paint application. All the benefits without the cost of masonry or the inconvenience of a lengthy curing time. The result: Tru Tudor elegance. Tru in architectural luxury. A Truly unforgettable first impression that lasts and lasts.

FEATURES/BENEFITS

- Quality engineered surface and core
- 30-year limited warranty
- Pre-primed for improved weatherability
- 4 ft. x 8 ft. panels for optimal versatility
- Matching TruWood Trim
- Installs 25-40% faster than cement or vinyl sidings
- Use for residential single-family, multi-family housing, remodeling and light commercial projects
- Easy and safe to install using normal woodworking tools. No silica dust.
- Ask us about our FSC® products (FSC®-C002971)

TREATED WITH

EcoGuard[®]

ZINC BORATE

- Resists mildew, rot and termite damage
- Naturally-occurring additive safe for use around children and pets

1/2 in. ADOBE™ PANEL SIDING SHIPLAP EDGE

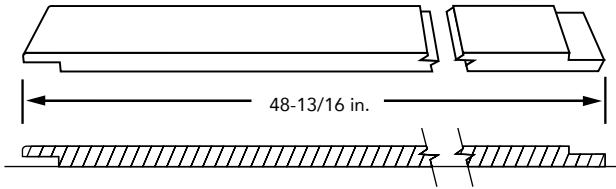

SPECIFICATIONS:

| Panel Size | Pc./ Unit | Sq. Ft. Coverage Per Piece | Approx Coverage Sq. Ft./ Unit | Approx. Sq. Ft. Needed To Cover 1,000 Sq. Ft. of Wall Area | Approx. Weight Lbs./Unit |
|--------------------------------|-----------|----------------------------|-------------------------------|--|--------------------------|
| 1/2 in. x 48-13/16 in. x 8 ft. | 37 | 32 | 1066 | 1100 | 2270 |

* Assumes 10% waste factor for cutting and fitting.
Adobe panels are shiplapped on the long edges and cut oversize to provide 48 in. net coverage when applied.

TruWood Siding and Trim meet the requirements of the following:

2024 International Building Code
2024 International Residential Code
ICC ESR-2588
ANSI A135.6-2012 (R2020)
Wildland-Urban Interface (WUI) Approved*

*WUI APPLICATION REQUIREMENTS

- Framing must not exceed 16 in. on center.
- Minimum 5/8 in. Type-X gypsum exterior sheathing is required.

Fire rating = Class C

R Value = 0.67 (hour) (Sq. Ft.) (Fahrenheit) per BTU

1/2 in. Panel Siding = No Shear Value

CAL. PROP 65 WARNING: Use of this product may result in exposure to wood dust, known to the State of California to cause cancer.

PROPER STORAGE AND HANDLING

- Store siding flat and support on stringers to avoid sagging and contact with the ground
- Siding must be covered and protected from the elements
- Stack no more than eight units high
- Allow siding to acclimatize to local conditions prior to installation

TO FIND YOUR NEAREST DISTRIBUTOR, WARRANTY INFORMATION, INSTALLATION INSTRUCTIONS, CARE AND MAINTENANCE INSTRUCTIONS, A SIDING CALCULATOR, OR TO VIEW OUR PRODUCTS ON SAMPLE HOMES USING OUR VISUALIZER TOOL, HEAD TO **TruWoodSiding.com**. CAN'T FIND WHAT YOU NEED? **800.417.3674**





ValuForm®

BENDER BOARD CONCRETE FORM

TruWood ValuForm flexible form boards are an engineered wood product designed for use in flatwork concrete forming applications. ValuForm installs easily and without special tools, providing Tru time and labor savings when creating curved corners and intricate designs.

FEATURES/BENEFITS

- Radius capability makes it ideal for highly-curved forming designs such as walkways, patios, pool aprons, driveways and more.
- Suitable for temporary landscape applications.
- Can be used with grade stakes, flexible, not brittle.
- Lightweight and flexible, easy to install without special tools. No silica dust.
- 16 ft. lengths minimize joints.
- Multiple uses for less job waste, more cost effective than other bender board forming materials.
- Ask us about our FSC® products (FSC®-C002971)

SPECIFICATIONS:

| Size | Pcs./ Unit | Approx. Weight Lbs./Unit |
|-------------------------------------|------------|--------------------------|
| 7/16 in. x 8 in. x 16 ft. unprimed | 252 | 4,380 |
| 7/16 in. x 12 in. x 16 ft. unprimed | 168 | 4,100 |
| 7/16 in. x 16 in. x 16 ft. unprimed | 126 | 4,630 |

- NOT TO BE USED AS SIDING
- NO WARRANTY
- **CAL. PROP 65 WARNING:**
Use of this product may result in exposure to wood dust, known in the state of California to cause cancer.

PROPER STORAGE AND HANDLING

- Store product flat and support on stringers to avoid sagging and contact with the ground
- Product must be covered and protected from the elements
- Stack no more than eight units high
- Allow product to acclimatize to local conditions prior to installation

FOR MORE INFORMATION, PLEASE CALL **800.417.3674** OR VISIT TruWoodSiding.com/resources.





Installation Manuals

Installation Instructions for TruWood Trim

Important:

Read and understand all pages of the installation instructions before starting the trim application.

For TruWood care and maintenance information, warranty information, and installation videos, visit our web site at: TruWoodSiding.com

USES FOR TRUWOOD TRIM

Truwood Trim is a non-structural decorative trim product. TruWood Trim may be used for all of the following trim applications:

- Fascia
- Rake board
- Frieze board
- Belly band
- Window trim (not to be used for window sills)
- Corners
- Column wrap
- Board and Batten
- Door trim

VAPOR BARRIERS, VENTILATION AND MOISTURE CONTROL

- Roofs, gutters, roof to wall transitions, windows, doors, decks and attachments shall be designed, flashed and installed to prevent moisture entry into the trim or wall cavity or accumulation of water against the trim other than ambient moisture.
- Trim must have 2 in. clearance from masonry, concrete, brick, stone, stucco or mortar, or be separated by metal flashing.
- A continuous vapor barrier rated 1 perm or less is required across the interior side of all walls to be sided.
- A vapor barrier rated 1 perm or less must be installed between the wood sill, wood framing and the foundation wall.
- A vapor barrier ground cover must be used in crawl spaces.
- Crawl spaces, attics and living spaces must be ventilated at least to the minimum specified in HUD standards.

FLASHING

- In areas where the bottom drip edge of the trim is adjacent to flashing, provide a minimum 3/8 in. gap between bottom drip edge of the trim and the flashing.
- Install flashing in a manner that creates proper out-sloping (see Fig. 4 and 5).
- Kick out flashing is required in areas where the roof and gutters are adjacent to the siding. Provide a 1 in. clearance between the gutter end and trim (see Fig. 7).

CUTTING

- Cut with conventional tools into the face to be exposed.
- Make sure to prime and paint all cut edges.
- Do not miter sides (edges) of trim. If trim is cut to fit around door and window openings, raw edges of trim must be primed and painted or sealed with approved sealant (see Fig. 6).
- 45 degree diagonal cuts are permitted around door and window openings (see Fig. 6).

FASTENING

- Use corrosion resistant boxhead nails with a minimum head diameter of 1/4 in. (10% variance allowed).
- Nail on each edge 12 in. o.c. alternating edges with nails placed a minimum of 1/2 in. from trim edge.
- Nails must penetrate wood framing 1-1/2 in.
- Fascia and rake boards must be applied over framing members that will allow proper nailing.
- Avoid countersinking nails or rupturing the surface of the siding. If countersinking occurs, seal nail prior to painting (see Fig. 1).
- Do not nail into trim edges.
- Fasten from end to end or center to end to avoid internal stress.
- Battens that do not fall over framing members must be applied with a ring shank nail.

- Butt joints must be located on framing members.
- When a scarf joint is used, two nails are required into solid wood framing on each side of the joint (see Fig. 2).

BUTT JOINTS

- All butt joints must be located over studs.
- Leave 3/16 in. gap at all butt joints.
- Metal joint covers are recommended at all butt joints and corners. This method minimizes long-term homeowner maintenance.
- In lieu of metal joint covers, seal the joint with the recommended sealant.

CLEARANCES

- Trim must have a minimum 2 in. separation from concrete, masonry, stucco, brick, mortar and stone or be separated by appropriate metal flashing.
- Trim must be 6 in. from soil or landscaping material.
- Where the trim meets the roof, it must be spaced a minimum of 2 in. from the plane of the roof and be properly flashed. The cut edge must be primed and painted.
- Vegetation must not be in direct contact with the trim.

SEALING

- Use the best quality flexible, paintable, mildew-resistant exterior grade sealant material that meets ASTM C920, Class 25 or higher.
- Seal around all openings such as window and door frames and at butt joints.
- Seal all overdriven nails (see Fig. 1).
- Seal or flash all horizontal trim material in a manner that creates proper out-sloping.

PAINTING

- Touch up damaged areas with premium acrylic latex primer or premium alkyd oil-based primer.
- Trim must be finish-painted within 90 days after installation. If trim is exposed for a longer period, reprime the trim.
- Trim must be clean and dry when paint is applied.
- Use only premium acrylic latex paint or premium alkyd oil-based paint containing an appropriate amount of mildewcide for local moisture conditions.
- For best performance, use 100% acrylic latex paints or 100% acrylic latex solid body (opaque) stain.
- Follow paint manufacturer's recommendations for engineered wood trim.
- A minimum of 4 dry mils, which includes 1 mil factory primer, is required. This is best achieved with two coats of finished paint.
- All cut ends must be well coated with primer and paint or sealant.

PROPER STORAGE

- Store trim flat and support it on stringers to avoid sagging and contact with the ground.
- Trim must be covered and protected from the elements.
- Allow trim to acclimatize to local conditions prior to installation.
- Do not re-manufacture the trim by ripping or routing.

CONSTRUCTION ESSENTIALS

- The structure must be constructed to meet local applicable building requirements, HUD minimum property standards or HUD manufactured housing construction and safety standards. Trim does not provide shear strength.

WARRANTY REQUIREMENTS

- The terms of the Limited Warranty require strict compliance with the installation instructions. These instructions are supplemental to applicable local building codes and standard building practices. Compliance with the most stringent of these is required. Architectural designs, plans and specifications must comply with these instructions.
- All deviations from the installation instructions must be pre-approved in writing by the Collins Products LLC Product Performance Manager.

INSTALLATION ERRORS THAT VOID THE WARRANTY

- Do not apply trim to a rain soaked structure.
- Trim should not be used to construct window sills.
- Do not apply trim that is wet. Wet trim can shrink after application and shrinkage is not covered by the TruWood warranty.
- Wet blown insulation is not allowed.
- Do not apply stucco or composite stucco products over the trim.
- Do not apply the trim to floating structures or buildings over water.
- Staples are not an acceptable fastening device.
- Do not apply to wall systems without conventional framing.
- Do not paint in wet or cold conditions.
- Do not use shake and shingle paints, low quality flat oil or alkyd paints, vinyl acetate (PVA), vinyl acrylic or vinyl acetate-acrylic co-polymer paints. These coatings do not adequately protect the trim.
- Do not remanufacture the trim by ripping or routing.

Note: This list is not intended to be inclusive of all errors that would void the warranty. These are just some examples.

KEY HOMEOWNER MAINTENANCE RESPONSIBILITIES

- Inspect and renew all sealant and immediately repair any water penetration issues every year.
- Maintain gutters and downspouts to avoid water cascading down walls.
- Ensure sprinkler patterns are directed away from structures.
- Follow paint manufacturer's recommendations for repainting and paint maintenance.

CODES AND STANDARDS

- TruWood Trim is designed to be used in compliance with all applicable building codes and standards.

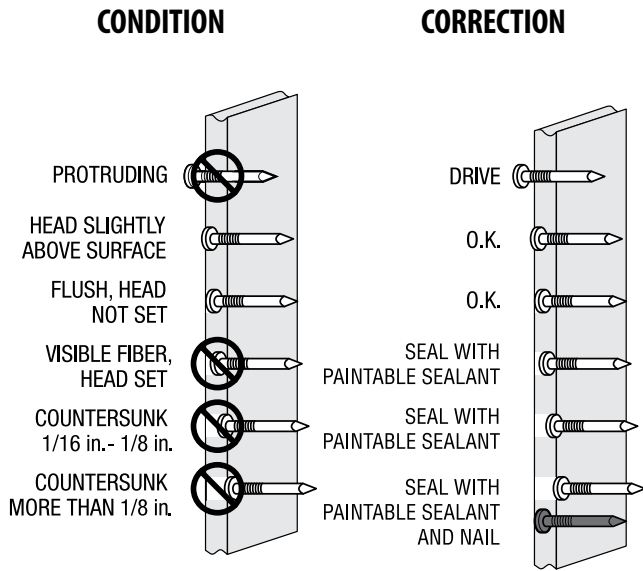

Figure 1

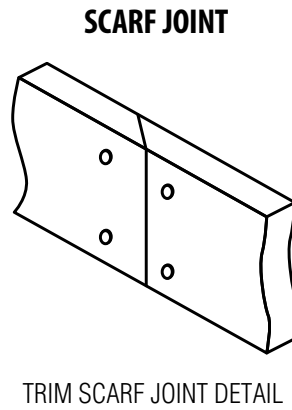

Figure 2

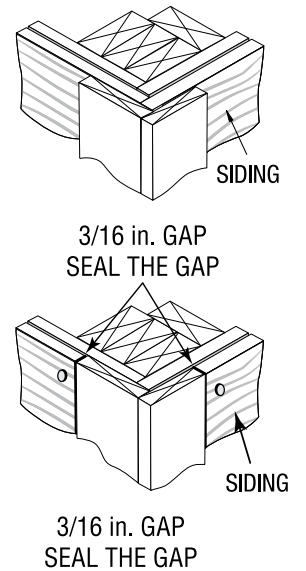

Figure 3

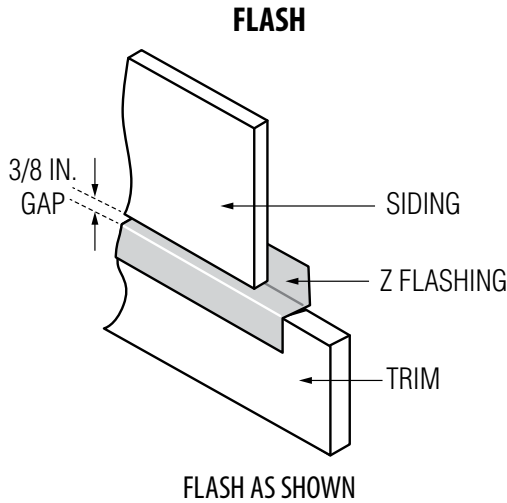

Figure 4

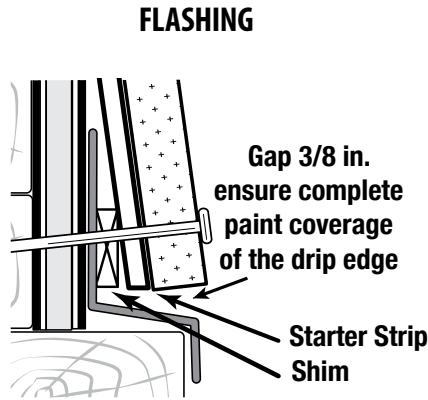

Figure 5

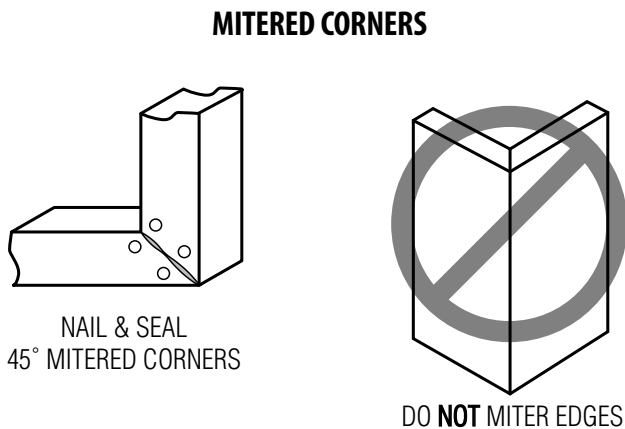

Figure 6

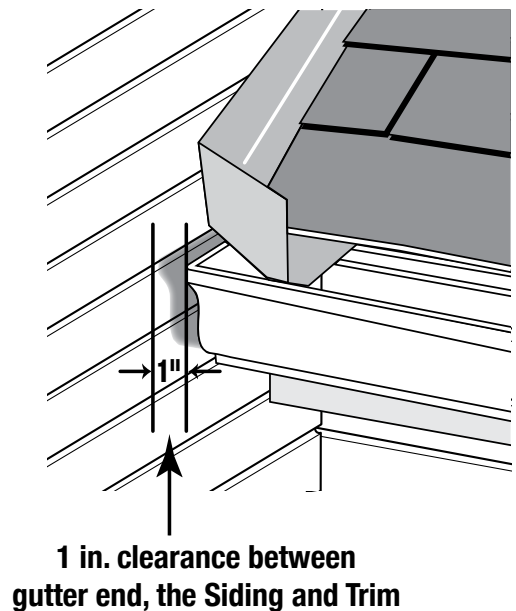
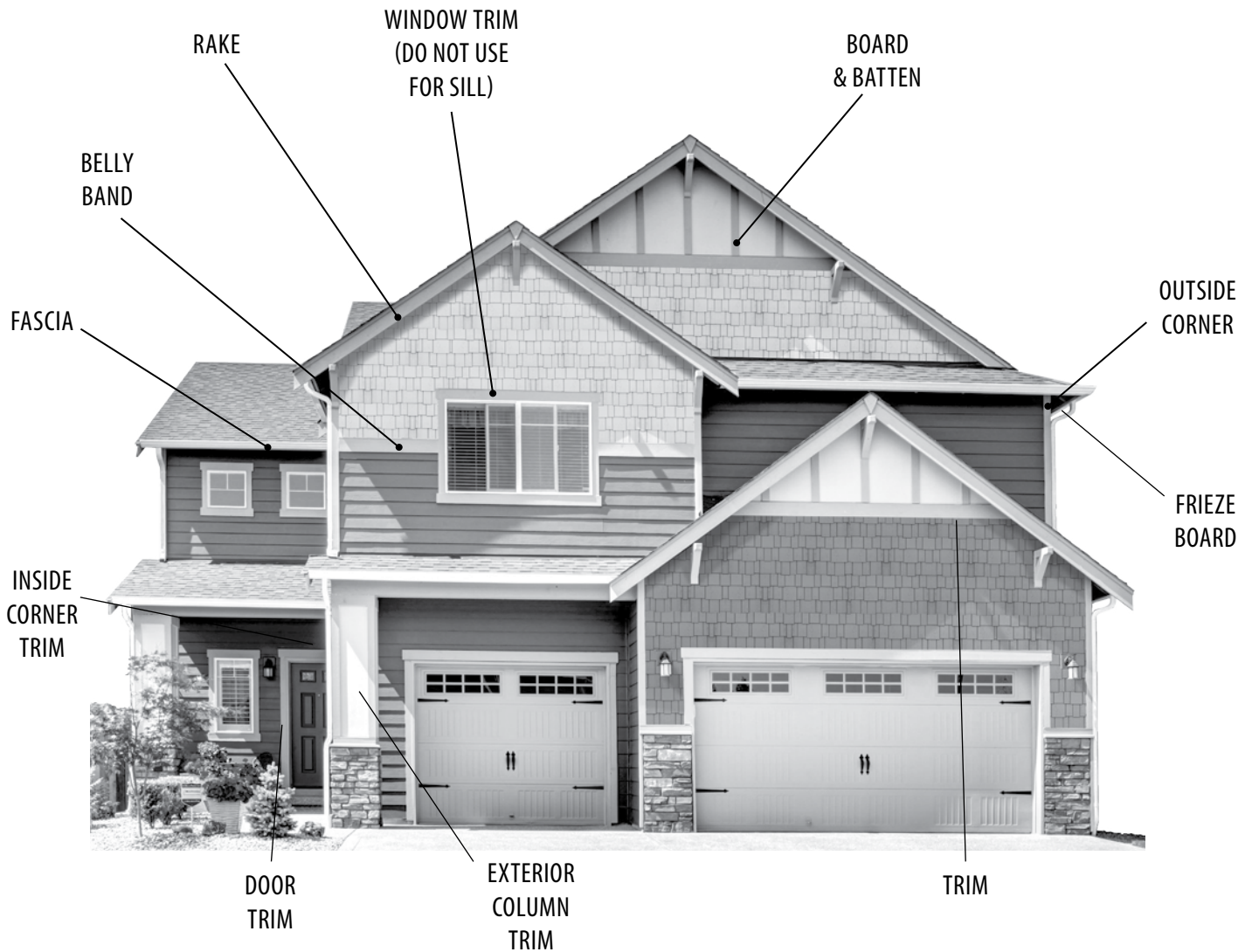

Figure 7



- Nails must penetrate wood framing 1-1/2 in.
- Do not use staples. Use only the nails specified in these instructions.
- Install a minimum 3/16 in. gap at butt joints and ends. Use only approved methods to protect joints areas.
- Trim must not be in direct contact with stucco, mortar, stone, brick, concrete or masonry.
- Apply trim in a method that will prevent moisture entry into the trim, siding or wall cavity.
- **Seal all exposed cut ends** using a method that will prevent moisture intrusion.
- Maintain the proper clearance from the trim bottom edge to the finished grade, walkways and adjacent to the roof lines.

Sales: 800.417.3674 • Warranty: 800.329.1219 • TruWoodSiding.com

Installation Instructions for Premium Lap Siding

Includes: 4 in., 5 in., 8 in. Cottage Lap[®]
TwelveFour Cottage Lap[®]
TwelveSix Cottage Lap[®]
and Channel Rustic

Important:

Read and understand all pages of the installation instructions before starting the siding application.

For TruWood care and maintenance information, warranty information, and installation videos, visit our web site at: TruWoodSiding.com

FRAMING

- Apply these lap siding products horizontally on walls and gables that meet racking requirements.
- Follow product specific nailing pattern (see Fig. 4).
- Framing must not exceed 16 in. on center (o.c.).
- Although not recommended, where 24 in. o.c. vertical framing is used, nail to framing 24 in. o.c. with intermediate nailing 12 in. o.c. to sheathing with a 6d galvanized ring shank nail. This effectively creates a 12 in. o.c. nailing schedule.

SHEATHING

- Sheathing is required for all siding products. Recommended sheathing is a minimum of 7/16 in. OSB or 1/2 in. exterior grade plywood.
- Foam sheathing or other composite sheathing may be substituted. Collins Products LLC will not be responsible for problems related to crushing of the foam during or after siding applications, or moisture accumulation in the wall cavity.

VAPOR BARRIERS, VENTILATION AND MOISTURE CONTROL

- Roofs, gutters, roof to wall transitions, windows, doors, decks and attachments shall be designed, flashed and installed to prevent moisture entry into the siding or wall cavity or accumulation of water against the siding other than ambient moisture.
- Siding must have 2 in. clearance from masonry, concrete, brick, stone, stucco or mortar, or be properly flashed (see Fig. 7).
- A continuous vapor barrier rated 1 perm or less is required across the interior side of all walls to be sided.
- A vapor barrier rated 1 perm or less must be installed between the wood sill, wood framing and the foundation wall.
- A vapor barrier ground cover must be used in crawl spaces.

- Crawl spaces, attics and living spaces must be ventilated at least to the minimum specified in HUD standards.

FLASHING

- In areas where the bottom drip edge of the siding is adjacent to flashing, provide a minimum 3/8 in. gap between bottom drip edge of the siding and the flashing (see Fig. 7).
- Install flashing in a manner that creates proper out-sloping (see Fig. 7).
- Kick out flashing is required in areas where the roof and gutters are adjacent to the siding. Provide a 1 in. clearance between the gutter end and the siding (see Fig. 8).

INSTALLING

- Start by ripping 2 or more inches off the top edge of the premium lap siding. The bottom portions of the ripped siding may be used for the top courses. Align starter strip with the bottom edge of the sill plate.
- Make sure to prime and paint all exposed cut edges.
- 16 in. Cottage Lap and Channel Rustic Sidings require 3 nails per board on all studs 16 in. o.c.
- 12 in. Cottage Lap Sidings require 2 nails per board on studs 16 in. o.c.
- Place nails 5/8 in. to 3/4 in. up from the drip edge and in the center of the lap. Make sure that drip edge nails penetrate both courses of siding and into studs. Do not nail in the groove (see Fig. 4).
- Periodic checks are necessary to ensure the horizontal lap remains level. Make adjustments as necessary.
- Vertical butt joints must be located only on studs.
- When butting siding to inside or outside corners, use a minimum 1 in. thick dry wood material. TruWood Trim is recommended (see Fig. 3).

FASTENING

- Use corrosion resistant boxhead nails with a minimum head diameter of 1/4 in. (10% variance allowed).
- Fastening must not exceed 16 in. o.c. (see Framing section for 24 in. o.c. stud spacing).
- All lap products require that the butt joints be located on the studs and nailed at the joints (see Fig. 2).
- Nails must penetrate wood framing 1-1/2 in.
- Avoid countersinking nails or rupturing the surface of the siding. If countersinking occurs, seal nail prior to painting (see Fig. 1).
- Fasten from end to end or center to end to avoid internal stress.
- Nailing schedule for soffit application of siding products must not exceed 16 in. o.c.
- For siding used as soffit material, the siding must be nailed 12 in. or 16 in. o.c. into the framing.

GAPS AND CORNERS

- Leave 3/16 in. gap around all doors, window frames and corners. Seal all gaps (see Fig. 2 and 3).

BUTT JOINTS

- All butt joints must be located over studs.
- Leave 3/16 in. gap at all butt joints (see Fig. 2).

Stacked Butt Joints (see Fig. 5)

Vertically aligning butt joints at a common location on the wall is strongly recommended. Joints should be gapped at least 3/16 in., sealed, then vertical trim is applied over the joints. This method minimizes long term homeowner maintenance.

Staggered Butt Joints (see Fig. 6)

If butt joints are staggered, vertical butt joint covers are required to protect the butt joints. Sealing butt joints in lieu of joint covers is

permitted but not recommended as it requires a higher degree of homeowner maintenance.

CLEARANCES

- Siding must have a minimum 2 in. separation from concrete or be appropriately flashed.
- Siding must be 6 in. from soil or landscaping material.
- Where the siding meets the roof, it must be spaced a minimum of 2 in. from the plane of the roof and be properly flashed. The cut edge must be primed and painted.
- Vegetation must not be in direct contact with the siding.

SEALING

- Use the best quality flexible, paintable, mildew-resistant exterior grade sealant material that meets ASTM C920, Class 25 or higher.
- Seal around all openings such as window and door frames and at butt joints.
- Seal all overdriven nails (see Fig. 1)
- Seal or flash all horizontal trim material in a manner that creates proper out-sloping.

PAINTING

- Touch up damaged areas with premium acrylic latex primer or premium alkyd oil-based primer.
- Siding must be finish-painted within 90 days after installation. If siding is exposed for a longer period, reprime the siding.
- Siding must be clean and dry when paint is applied.
- Use only premium acrylic latex paint or premium alkyd oil-based paint containing an appropriate amount of mildewcide for local moisture conditions.
- For best performance, use 100% acrylic latex paints or 100% acrylic latex solid body (opaque) stain.

- Follow paint manufacturer’s recommendations for engineered wood siding.
- A minimum of 4 dry mils, which includes 1 mil factory primer, is required. This is best achieved with two coats of finished paint.
- Drip edges and grooves must be well coated.
- All surfaces and exposed cut edges must be painted in place.

PROPER STORAGE

- Store siding flat and support it on stringers to avoid sagging and contact with the ground.
- Siding must be covered and protected from the elements.
- Allow siding to acclimatize to local conditions prior to installation.

CONSTRUCTION ESSENTIALS

- The structure must be constructed to meet local applicable building requirements, HUD minimum property standards or HUD manufactured housing construction and safety standards. Lap siding does not provide shear strength.

WARRANTY REQUIREMENTS

- The terms of the Limited Warranty require strict compliance with the installation instructions. These instructions are supplemental to applicable local building codes and standard building practices. Compliance with the most stringent of these is required. Architectural designs, plans and specifications must comply with these instructions.
- All deviations from the installation instructions must be pre-approved in writing by the Collins Products LLC Product Performance Manager.

INSTALLATION ERRORS THAT VOID THE WARRANTY

- Do not apply siding to a rain soaked structure.
- Do not apply siding that is wet. Wet siding can shrink after application and shrinkage is not covered by the TruWood warranty.
- Wet blown insulation is not allowed.
- Do not apply stucco or composite stucco products over the siding.
- Do not apply the siding to floating structures or buildings over water.
- Staples are not an acceptable fastening device.
- Do not apply to wall systems without conventional framing.
- Do not bevel cut the siding edges at butt joints.
- Do not paint in wet or cold conditions.
- Do not use shake and shingle paints, low quality flat oil or alkyd paints, vinyl acetate (PVA), vinyl acrylic or vinyl acetate-acrylic co-polymer paints. These coatings do not adequately protect the siding.
- Do not blind nail siding.

Note: This list is not intended to be inclusive of all errors that would void the warranty. These are just some examples.

KEY HOMEOWNER MAINTENANCE RESPONSIBILITIES

- Inspect and renew all sealant and immediately repair any water penetration issues every year.
- Maintain gutters and downspouts to avoid water cascading down walls.
- Ensure sprinkler patterns are directed away from structures.
- Follow paint manufacturer’s recommendations for repainting and paint maintenance.

CONDITION

CORRECTION

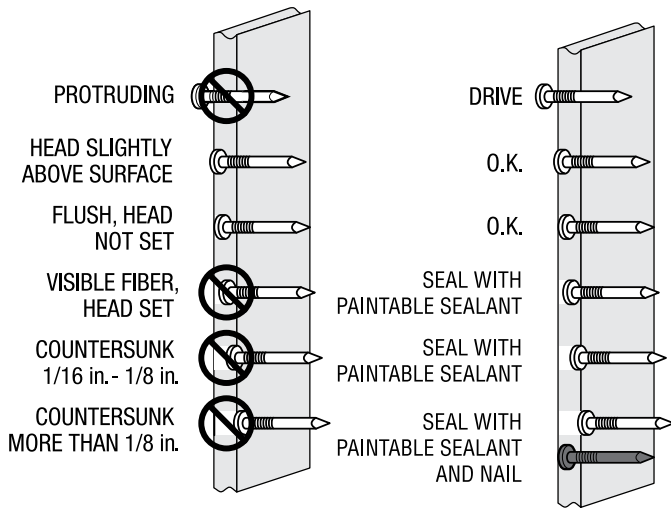

Figure 1

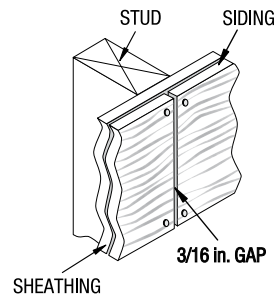

Figure 2

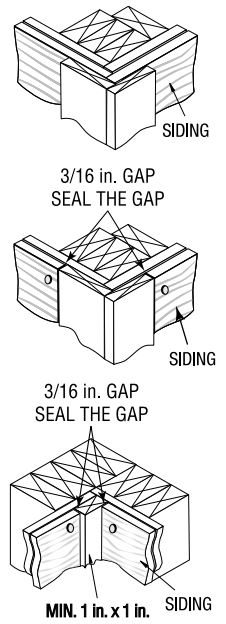

Figure 3

PREMIUM LAP SIDING NAILING

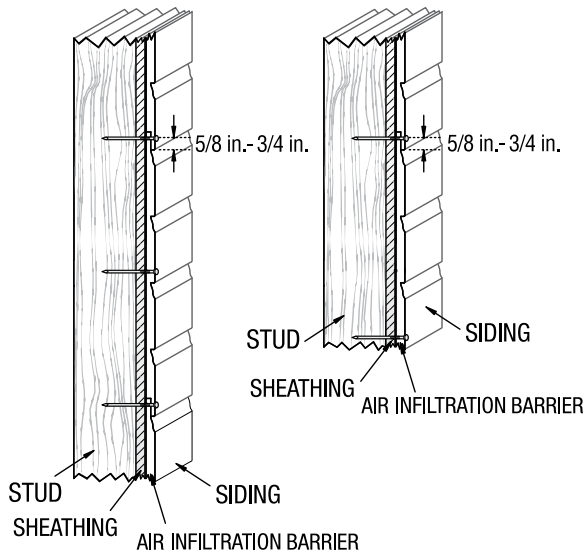

Figure 4

VERTICALLY ALIGNED JOINTS

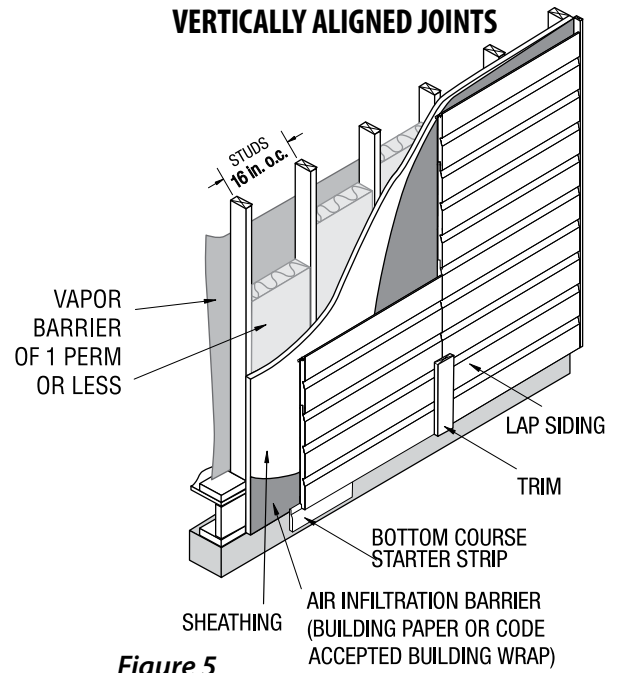

Figure 5

STAGGERED JOINTS

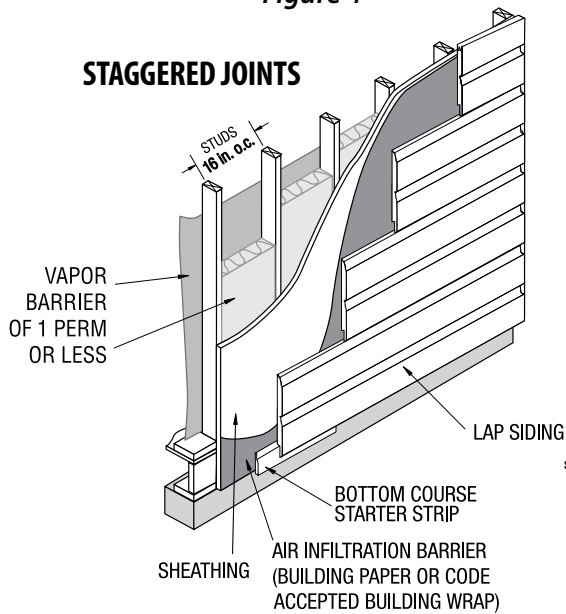

Figure 6

FLASHING

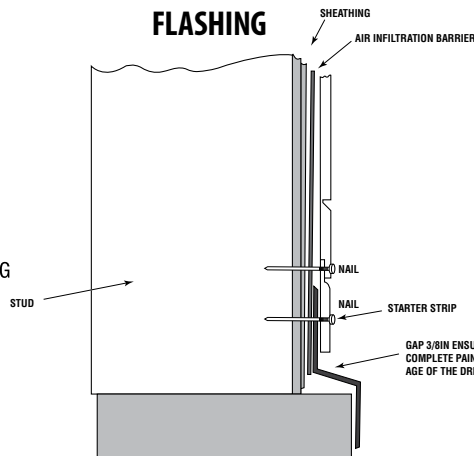

Figure 7

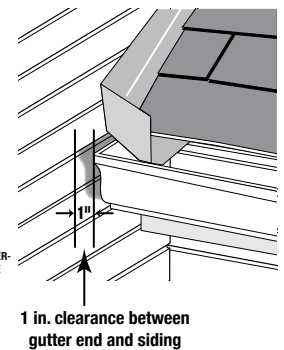

Figure 8

- Apply siding over approved structural sheathing.
- Maximum nail spacing is 16 in. on center.
- Nails must penetrate wood framing 1-1/2 in.
- Do not use staples. Use only the nails specified in these instructions.
- Install a minimum 3/16 in. gap at butt joints and ends. Use only approved methods to protect joints areas.
- Siding must not be in direct contact with stucco, mortar, stone, brick, concrete or masonry.
- Apply siding in a method that will prevent moisture entry into the siding or wall cavity.
- Seal all exposed cut ends using a method that will prevent moisture intrusion.
- Maintain the proper clearance from the siding bottom drip edge to the finished grade, walkways and adjacent to the roof lines.

CODES AND STANDARDS

TruWood® Siding meets the requirements of the following codes and standards:

- 2024 International Building Code
- 2024 International Residential Code
- ICC ESR-2588
- ANSI A135.6-2012 (R2020)
- Wildland-Urban Interface (WUI) Approved*

***WUI APPLICATION REQUIREMENTS**

- Framing must not exceed 16 in. on center.
- Minimum 5/8 in. Type-X gypsum exterior sheathing is required.

Installation Instructions for Bevel Edge Lap and Self-Aligning Lap Siding

7/16 in. Bevel Edge Laps Include:

6 in., 8 in., 9 1/2 in., 12 in. Old Mill, and 8 in.
Smooth Lap

1/2 in. Self-Aligning Include:

8 in. and 12 in. Old Mill, Cedar Shake Lap

Important:

**Read and understand all pages of
the installation instructions before
starting the siding application.**

**For TruWood care and maintenance information,
warranty information, and installation videos,
visit our web site at: TruWoodSiding.com**

FRAMING

- Apply these lap siding products horizontally on walls and gables that meet racking requirements.
- Follow product specific nailing pattern (see Fig. 4).
- Framing must not exceed 16 in. on center (o.c.).
- Although not recommended, where 24 in. o.c. vertical framing is used, nail to framing 24 in. o.c. with intermediate nailing 12 in. o.c. to sheathing with a 6d galvanized ring shank nail. This effectively creates a 12 in. o.c. nailing schedule.

SHEATHING

- Sheathing is required for all siding products. Recommended sheathing is a minimum of 7/16 in. OSB or 1/2 in. exterior grade plywood.
- Foam sheathing or other composite sheathing may be substituted. Collins Products LLC will not be responsible for problems related to crushing of the foam during or after siding applications, or moisture accumulation in the wall cavity.

VAPOR BARRIERS, VENTILATION AND MOISTURE CONTROL

- Roofs, gutters, roof to wall transitions, windows, doors, decks and attachments shall be designed, flashed and installed to prevent moisture entry into the siding or wall cavity or accumulation of water against the siding other than ambient moisture.
- Siding must have 2 in. clearance from masonry, concrete, brick, stone, stucco or mortar, or be properly flashed (see Fig. 7).
- A continuous vapor barrier rated 1 perm or less is required across the interior side of all walls to be sided.
- A vapor barrier rated 1 perm or less must be installed between the wood sill, wood framing and the foundation wall.
- A vapor barrier ground cover must be used in crawl spaces.

- Crawl spaces, attics and living spaces must be ventilated at least to the minimum specified in HUD standards.

FLASHING

- In areas where the bottom drip edge of the siding is adjacent to flashing, provide a minimum 3/8 in. gap between bottom drip edge of the siding and the flashing (see Fig. 7).
- Install flashing in a manner that creates proper out-sloping (see Fig. 7).
- Kick out flashing is required in areas where the roof and gutters are adjacent to the siding. Provide a 1 in. clearance between the gutter end and the siding (see Fig. 8).

INSTALLING

- Start by ripping 1 1/2 or more inches off the top edge of the siding. The bottom portions of the ripped siding may be used for the top courses. Align starter strip with the bottom edge of the sill plate.
- Make sure to prime and paint all exposed cut edges.
- For Standard Lap products overlap successive courses at least 1 in.
- Place nails 5/8 in. to 3/4 in. up from the drip edge. Make sure that nails penetrate through both pieces of siding and into studs (see Fig. 4).
- Periodic checks are necessary to ensure the horizontal lap remains level. Make adjustments as necessary.
- Vertical butt joints must be located only on studs. Each piece of siding must be nailed top and bottom to studs.
- When butting siding to inside or outside corners, use a minimum 1 in. thick dry wood material. TruWood Trim is recommended (see Fig. 3).

FASTENING

- Use corrosion resistant boxhead nails with a minimum head diameter of 1/4 in. (10% variance allowed).
- Fastening must not exceed 16 in. o.c. (see Framing section for 24 in. o.c. stud spacing).
- All lap products require that the butt joints be located on the studs and nailed at the joints (see Fig. 2).
- Nails must penetrate wood framing 1-1/2 in.
- Avoid countersinking nails or rupturing the surface of the siding. If countersinking occurs, seal nail prior to painting (see Fig. 1).
- Fasten from end to end or center to end to avoid internal stress.
- Nailing schedule for soffit application of siding products must not exceed 16 in. o.c.
- For siding used as soffit material, the siding must be nailed 12 in. or 16 in. o.c. into the framing.

GAPS AND CORNERS

- Leave 3/16 in. gap around all doors, window frames and corners. Seal all gaps (see Fig. 2 & 3).

BUTT JOINTS

- All butt joints must be located over studs.
- Leave 3/16 in. gap at all butt joints (see Fig. 2).

Stacked Butt Joints (see Fig. 5)

Vertically aligning butt joints at a common location on the wall is strongly recommended. Joints should be gapped at least 3/16 in., sealed, then vertical trim is applied over the joints. This method minimizes long term homeowner maintenance.

Staggered Butt Joints (see Fig. 6)

If butt joints are staggered, vertical butt joint covers are required to protect the butt joints. Sealing butt joints in lieu of joint covers is permitted but not recommended as it requires a higher degree of homeowner maintenance.

CLEARANCES

- Siding must have a minimum 2 in. separation from concrete or be appropriately flashed.
- Siding must be 6 in. from soil or landscaping material.
- Where the siding meets the roof, it must be spaced a minimum of 2 in. from the plane of the roof and be properly flashed. The cut edge must be primed and painted.
- Vegetation must not be in direct contact with the siding.

SEALING

- Use the best quality flexible, paintable, mildew-resistant exterior grade sealant material that meets ASTM C920, Class 25 or higher.
- Seal around all openings such as window and door frames and at butt joints.
- Seal all overdriven nails (see Fig. 1)
- Seal or flash all horizontal trim material in a manner that creates proper out-sloping.

PAINTING

- Touch up damaged areas with premium acrylic latex primer or premium alkyd oil-based primer.
- Siding must be finish-painted within 90 days after installation. If siding is exposed for a longer period, reprime the siding.
- Siding must be clean and dry when paint is applied.
- Use only premium acrylic latex paint or premium alkyd oil-based paint containing an appropriate amount of mildewcide for local moisture conditions.
- For best performance, use 100% acrylic latex paints or 100% acrylic latex solid body (opaque) stain.
- Follow paint manufacturer's recommendations for engineered wood siding.

- A minimum of 4 dry mils, which includes 1 mil factory primer, is required. This is best achieved with two coats of finished paint.
- Drip edges and grooves must be well coated.
- All surfaces and exposed cut edges must be painted in place.

PROPER STORAGE

- Store siding flat and support it on stringers to avoid sagging and contact with the ground.
- Siding must be covered and protected from the elements.
- Allow siding to acclimatize to local conditions prior to installation.

CONSTRUCTION ESSENTIALS

- The structure must be constructed to meet local applicable building requirements, HUD minimum property standards or HUD manufactured housing construction and safety standards. Lap siding does not provide shear strength.

WARRANTY REQUIREMENTS

- The terms of the Limited Warranty require strict compliance with the installation instructions. These instructions are supplemental to applicable local building codes and standard building practices. Compliance with the most stringent of these is required. Architectural designs, plans and specifications must comply with these instructions.
- All deviations from the installation instructions must be pre-approved in writing by the Collins Products LLC Product Performance Manager.

INSTALLATION ERRORS THAT VOID THE WARRANTY

- Do not apply siding to a rain soaked structure.
- Do not apply siding that is wet. Wet siding can shrink after application and shrinkage is not covered by the TruWood warranty.
- Wet blown insulation is not allowed.
- Do not apply stucco or composite stucco products over the siding.
- Do not apply the siding to floating structures or buildings over water.
- Staples are not an acceptable fastening device.
- Do not apply to wall systems without conventional framing.
- Do not bevel cut the siding edges at butt joints.
- Do not paint in wet or cold conditions.
- Do not use shake and shingle paints, low quality flat oil or alkyd paints, vinyl acetate (PVA), vinyl acrylic or vinyl acetate-acrylic co-polymer paints. These coatings do not adequately protect the siding.
- Do not blind nail siding.

Note: This list is not intended to be inclusive of all errors that would void the warranty. These are just some examples.

KEY HOMEOWNER MAINTENANCE RESPONSIBILITIES

- Inspect and renew all sealant and immediately repair any water penetration issues every year.
- Maintain gutters and downspouts to avoid water cascading down walls.
- Ensure sprinkler patterns are directed away from structures.
- Follow paint manufacturer's recommendations for repainting and paint maintenance.

CONDITION

CORRECTION

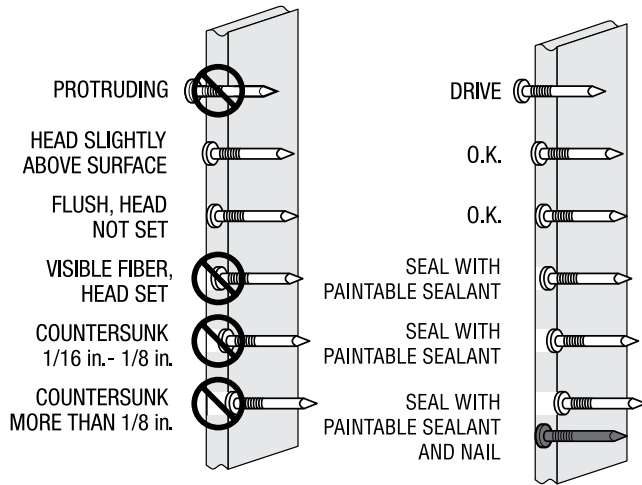

Figure 1

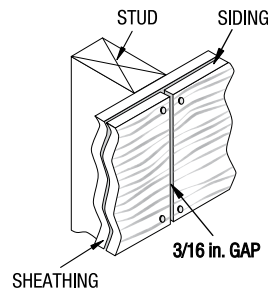

Figure 2

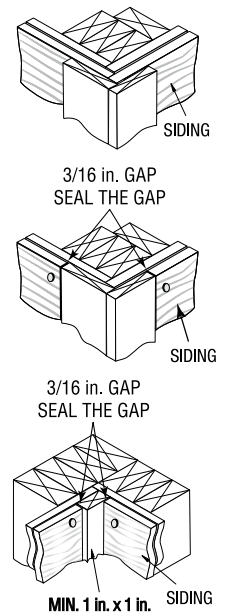

Figure 3

LAP SIDING NAILING

SELF-ALIGNING LAP SIDING NAILING

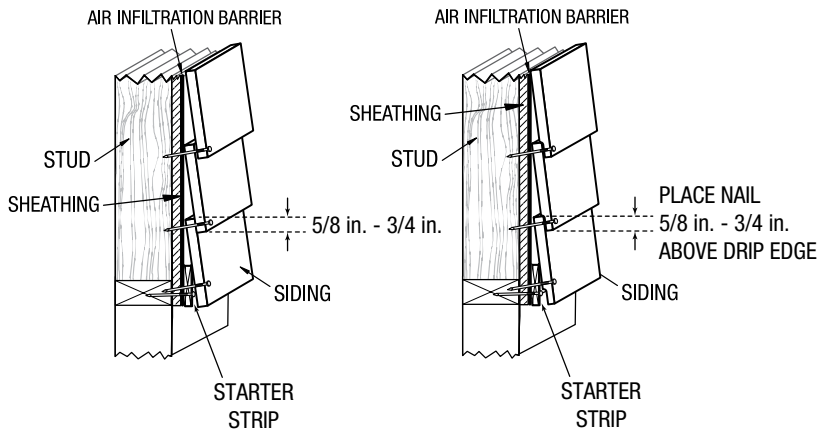

Figure 4

VERTICALLY ALIGNED JOINTS

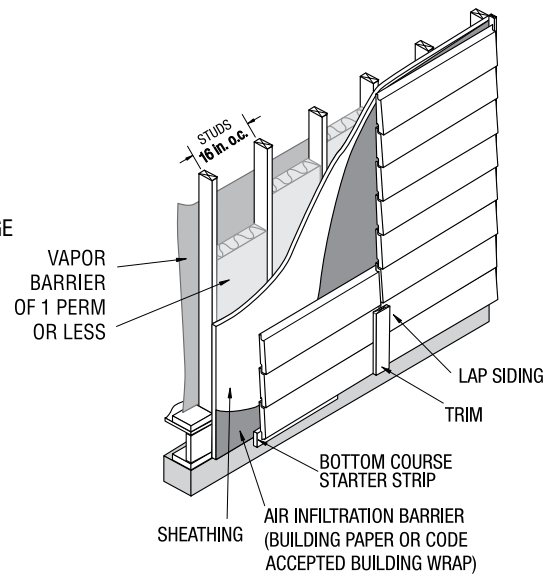

Figure 5

STAGGERED JOINTS

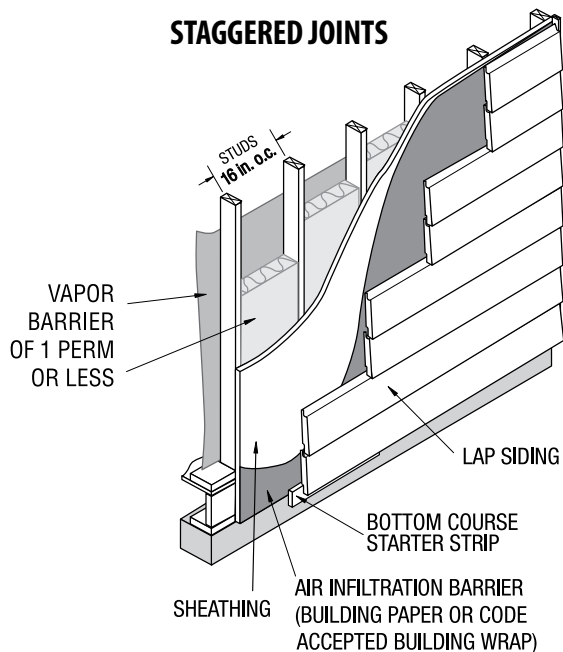

Figure 6

FLASHING

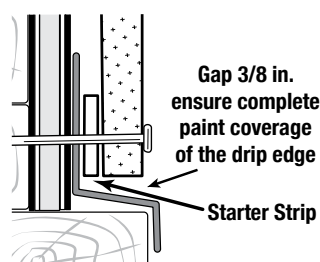
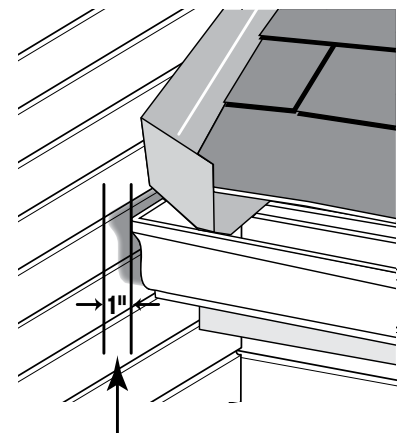

Figure 7



1 in. clearance between gutter end and siding

Figure 8

- Apply siding over approved structural sheathing.
- Maximum nail spacing is 16 in. on center.
- Nails must penetrate wood framing 1-1/2 in.
- Do not use staples. Use only the nails specified in these instructions.
- Install a minimum 3/16 in. gap at butt joints and ends. Use only approved methods to protect joints areas.
- Siding must not be in direct contact with stucco, mortar, stone, brick, concrete or masonry.
- Apply siding in a method that will prevent moisture entry into the siding or wall cavity.
- Seal all exposed cut ends using a method that will prevent moisture intrusion.
- Maintain the proper clearance from the siding bottom drip edge to the finished grade, walkways and adjacent to the roof lines.

CODES AND STANDARDS

TruWood® Siding meets the requirements of the following codes and standards:

- 2024 International Building Code
- 2024 International Residential Code
- ICC ESR-2588
- ANSI A135.6-2012 (R2020)
- Wildland-Urban Interface (WUI) Approved*

***WUI APPLICATION REQUIREMENTS**

- Framing must not exceed 16 in. on center.
- Minimum 5/8 in. Type-X gypsum exterior sheathing is required.

Installation Instructions for Sure Lock™ Lap Siding with Concealed Nailing System

Includes: 8 in. Sure Lock™
Sure Lock Six Cottage Lap® and
12 in. Sure Lock V-Rustic®

Important:

**Read and understand all pages of
the installation instructions before
starting the siding application.**

**For TruWood care and maintenance information,
warranty information, and installation videos,
visit our web site at: TruWoodSiding.com**

FRAMING

- Apply these lap siding products horizontally on walls and gables that meet racking requirements.
- Follow product specific nailing pattern (see Fig. 4).
- Framing must not exceed 16 in. on center (o.c.).
- Although not recommended, where 24 in. o.c. vertical framing is used, nail to framing 24 in. o.c. with intermediate nailing 12 in. o.c. to sheathing with a 6d galvanized ring shank nail. This effectively creates a 12 in. o.c. nailing schedule.

SHEATHING

- Sheathing is required for all siding products. Recommended sheathing is a minimum of 7/16 in. OSB or 1/2 in. exterior grade plywood.
- Foam sheathing or other composite sheathing may be substituted. Collins Products LLC will not be responsible for problems related to crushing of the foam during or after siding applications, or moisture accumulation in the wall cavity.

VAPOR BARRIERS, VENTILATION AND MOISTURE CONTROL

- Roofs, gutters, roof to wall transitions, windows, doors, decks and attachments shall be designed, flashed and installed to prevent moisture entry into the siding or wall cavity or accumulation of water against the siding other than ambient moisture.
- Siding must have 2 in. clearance from masonry, concrete, brick, stone, stucco or mortar, or be properly flashed (see Fig. 7).
- A continuous vapor barrier rated 1 perm or less is required across the interior side of all walls to be sided.
- A vapor barrier rated 1 perm or less must be installed between the wood sill, wood framing and the foundation wall.
- A vapor barrier ground cover must be used in crawl spaces.

- Crawl spaces, attics and living spaces must be ventilated at least to the minimum specified in HUD standards.

FLASHING

- In areas where the bottom drip edge of the siding is adjacent to flashing, provide a minimum 3/8 in. gap between bottom drip edge of the siding and the flashing (see Fig. 7).
- Install flashing in a manner that creates proper out-sloping (see Fig. 7).
- Kick out flashing is required in areas where the roof and gutters are adjacent to the siding. Provide a 1 in. clearance between the gutter end and the siding (see Fig. 8).

INSTALLING

- Start by ripping 2 or more inches off the top edge of the Sure Lock siding to provide an interlocking starter strip. Align starter strip with the bottom edge of the sill plate. The bottom portions of the ripped siding may be used for the top courses.
- Make sure to prime and paint all exposed cut edges.
- Sure Lock requires one nail per lap piece on all studs 16 in. o.c. Make sure each nail is placed precisely on the scored nailing guideline. This ensures that the nail head is properly concealed and does not penetrate the interlocking grooves. The top of the nail must be flush to ensure ease of interlock during application (see Fig. 4).
- Periodic checks are necessary to ensure the horizontal lap remains level. Make adjustments as necessary.
- Vertical butt joints must be located only on studs.
- When butting siding to inside or outside corners, use a minimum 1 in. thick dry wood material (see Fig. 3).

FASTENING

- Use corrosion resistant boxhead nails with a minimum head diameter of 1/4 in. (10% variance allowed).
- Fastening must not exceed 16 in. o.c. (see Framing section for 24 in. o.c. stud spacing).
- All lap products require that the butt joints be located on the studs and nailed at the joints (see Fig. 2).
- Nails must penetrate wood framing 1-1/2 in.
- Avoid countersinking nails or rupturing the surface of the siding. If countersinking occurs, seal nail prior to painting (see Fig. 1).
- Fasten from end to end or center to end to avoid internal stress.
- Nailing schedule for soffit application of siding products must not exceed 16 in. o.c.
- For siding used as soffit material, the siding must be nailed 12 in. or 16 in. o.c. into the framing.

GAPS AND CORNERS

- Leave 3/16 in. gap around all doors, window frames and corners. Seal all gaps (see Fig. 2 and 3).

BUTT JOINTS

- All butt joints must be located over studs.
- Leave 3/16 in. gap at all butt joints (see Fig. 2).

Stacked Butt Joints (see Fig. 5)

Vertically aligning butt joints at a common location on the wall is strongly recommended. Joints should be gapped at least 3/16 in, sealed, then vertical trim is applied over the joints. This method minimizes long term homeowner maintenance.

Staggered Butt Joints (see Fig. 6)

If butt joints are staggered, vertical butt joint covers are required to protect the butt joints. Sealing butt joints in lieu of joint covers is permitted but not recommended as it requires a higher degree of homeowner maintenance.

CLEARANCES

- Siding must have a minimum 2 in. separation from concrete or be appropriately flashed.
- Siding must be 6 in. from soil or landscaping material.
- Where the siding meets the roof, it must be spaced a minimum of 2 in. from the plane of the roof and be properly flashed. The cut edge must be primed and painted.
- Vegetation must not be in direct contact with the siding.

SEALING

- Use the best quality flexible, paintable, mildew-resistant exterior grade sealant material that meets ASTM C920, Class 25 or higher.
- Seal around all openings such as window and door frames and at butt joints.
- Seal all overdriven nails (see Fig. 1).
- Seal or flash all horizontal trim material in a manner that creates proper out-sloping.

PAINTING

- Touch up damaged areas with premium acrylic latex primer or premium alkyd oil-based primer.
- Siding must be finish-painted within 90 days after installation. If siding is exposed for a longer period, reprime the siding.
- Siding must be clean and dry when paint is applied.
- Use only premium acrylic latex paint or premium alkyd oil-based paint containing an appropriate amount of mildewcide for local moisture conditions.
- For best performance, use 100% acrylic latex paints or 100% acrylic latex solid body (opaque) stain.
- Follow paint manufacturer's recommendations for engineered wood siding.

- A minimum of 4 dry mils, which includes 1 mil factory primer, is required. This is best achieved with two coats of finished paint.
- Drip edges and grooves must be well coated.
- All surfaces and exposed cut edges must be painted in place.

PROPER STORAGE

- Store siding flat and support it on stringers to avoid sagging and contact with the ground.
- Siding must be covered and protected from the elements.
- Allow siding to acclimatize to local conditions prior to installation.

CONSTRUCTION ESSENTIALS

- The structure must be constructed to meet local applicable building requirements, HUD minimum property standards or HUD manufactured housing construction and safety standards. Lap siding does not provide shear strength.

WARRANTY REQUIREMENTS

- The terms of the Limited Warranty require strict compliance with the installation instructions. These instructions are supplemental to applicable local building codes and standard building practices. Compliance with the most stringent of these is required. Architectural designs, plans and specifications must comply with these instructions.
- All deviations from the installation instructions must be pre-approved in writing by the Collins Products LLC Product Performance Manager.

INSTALLATION ERRORS THAT VOID THE WARRANTY

- Do not apply siding to a rain soaked structure.
- Do not apply siding that is wet. Wet siding can shrink after application and shrinkage is not covered by the TruWood warranty.
- Wet blown insulation is not allowed.
- Do not apply stucco or composite stucco products over the siding.
- Do not apply the siding to floating structures or buildings over water.
- Staples are not an acceptable fastening device.
- Do not apply to wall systems without conventional framing.
- Do not bevel cut the siding edges at butt joints.
- Do not paint in wet or cold conditions.
- Do not use shake and shingle paints, low quality flat oil or alkyd paints, vinyl acetate (PVA), vinyl acrylic or vinyl acetate-acrylic co-polymer paints. These coatings do not adequately protect the siding.

Note: This list is not intended to be inclusive of all errors that would void the warranty. These are just some examples.

KEY HOMEOWNER MAINTENANCE RESPONSIBILITIES

- Inspect and renew all sealant and immediately repair any water penetration issues every year.
- Maintain gutters and downspouts to avoid water cascading down walls.
- Ensure sprinkler patterns are directed away from structures.
- Follow paint manufacturer's recommendations for repainting and paint maintenance.

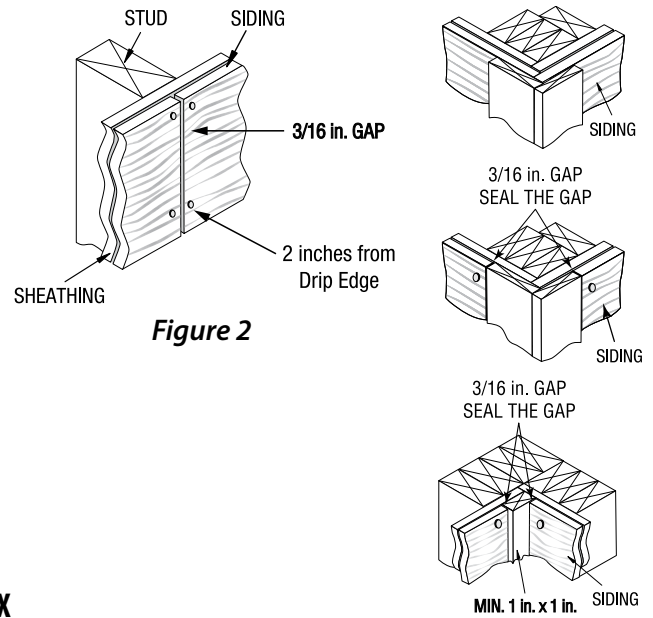
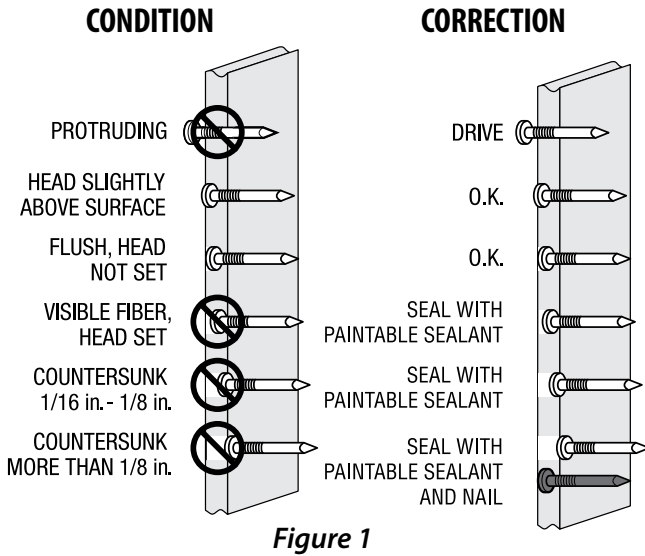

8 IN. SURE LOCK™ NAILING

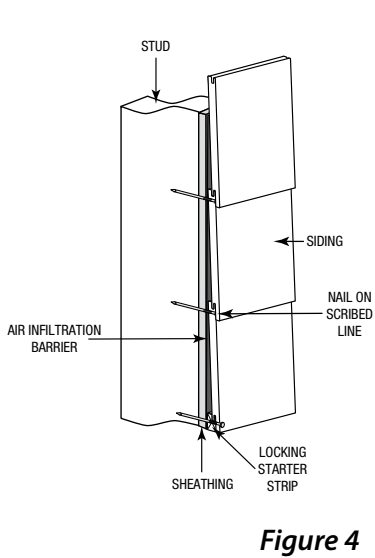

SURE LOCK SIX COTTAGE LAP® NAILING

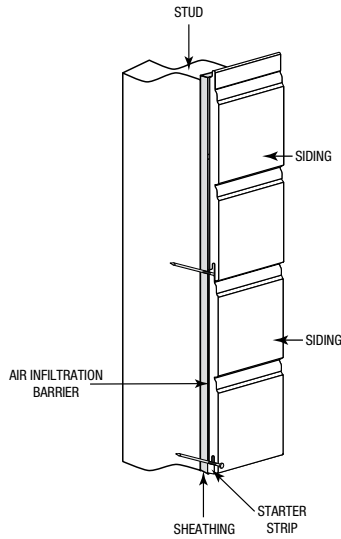

SURE LOCK SIX COTTAGE LAP® SIDING VERTICALLY ALIGNED JOINTS

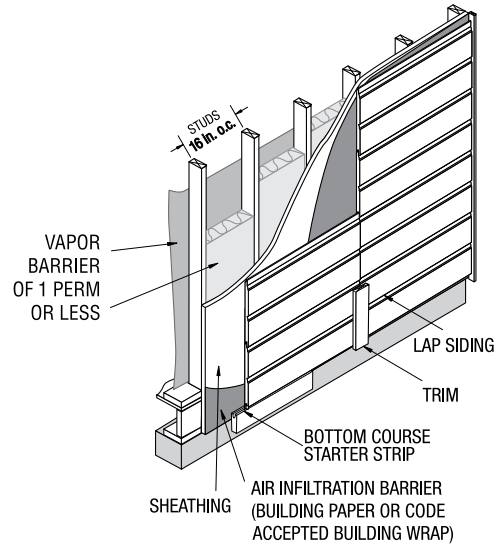

SURE LOCK LAP SIDING STAGGERED JOINTS

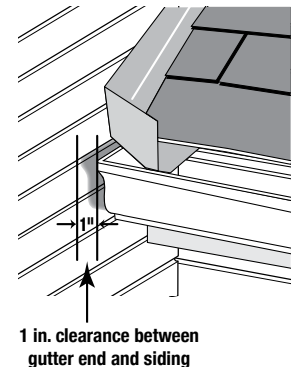
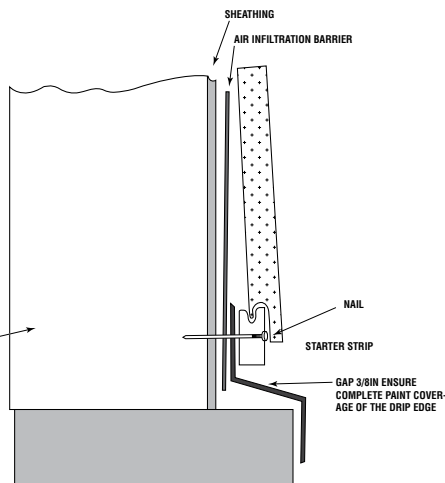
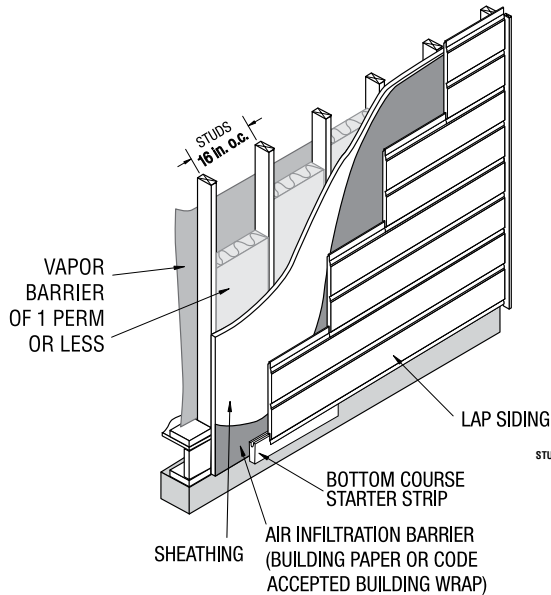

Figure 6

Figure 7

Figure 8

- Apply siding over approved structural sheathing.
- Maximum nail spacing is 16 in. on center.
- Nails must penetrate wood framing 1-1/2 in.
- Do not use staples. Use only the nails specified in these instructions.
- Install a minimum 3/16 in. gap at butt joints and ends. Use only approved methods to protect joint areas.
- Siding must not be in direct contact with stucco, mortar, stone, brick, concrete or masonry.
- Apply siding in a method that will prevent moisture entry into the siding or wall cavity.
- Seal all exposed cut ends using a method that will prevent moisture intrusion.
- Maintain the proper clearance from the siding bottom drip edge to the finished grade, walkways and adjacent to the roof lines.

CODES AND STANDARDS

TruWood® Siding meets the requirements of the following codes and standards:

- 2024 International Building Code
- 2024 International Residential Code
- ICC ESR-2588
- ANSI A135.6-2012 (R2020)
- Wildland-Urban Interface (WUI) Approved*

***WUI APPLICATION REQUIREMENTS**

- Framing must not exceed 16 in. on center.
- Minimum 5/8 in. Type-X gypsum exterior sheathing is required.

Installation Instructions for Old Mill[®] Shingle and Designer Shake Lap Siding

Includes: Cove, Craftsmen Staggered, Diamond,
Fish Scale, Octagon, Round and
Old Mill Shingle Lap

Important:

**Read and understand all pages of
the installation instructions before
starting the siding application.**

**For TruWood care and maintenance information,
warranty information, and installation videos,
visit our web site at: TruWoodSiding.com**

FRAMING

- Apply these lap siding products horizontally on walls and gables that meet racking requirements.
- Follow product specific nailing pattern (see Fig. 5).
- Framing must not exceed 16 in. on center (o.c.).
- Although not recommended, where 24 in. o.c. vertical framing is used, nail to framing 24 in. o.c. with intermediate nailing 12 in. o.c. to sheathing with a 6d galvanized ring shank nail. This effectively creates a 12 in. o.c. nailing schedule.

SHEATHING

- Sheathing is required for all siding products. Recommended sheathing is a minimum of 7/16 in. OSB or 1/2 in. exterior grade plywood.
- Foam sheathing or other composite sheathing may be substituted. Collins Products LLC will not be responsible for problems related to crushing of the foam during or after siding applications, or moisture accumulation in the wall cavity.

VAPOR BARRIERS, VENTILATION AND MOISTURE CONTROL

- Roofs, gutters, roof to wall transitions, windows, doors, decks and attachments shall be designed, flashed and installed to prevent moisture entry into the siding or wall cavity or accumulation of water against the siding other than ambient moisture.
- Siding must have 2 in. clearance from masonry, concrete, brick, stone, stucco or mortar, or be properly flashed (see Fig. 8).
- A continuous vapor barrier rated 1 perm or less is required across the interior side of all walls to be sided.
- A vapor barrier rated 1 perm or less must be installed between the wood sill, wood framing and the foundation wall.
- A vapor barrier ground cover must be used in crawl spaces.
- Crawl spaces, attics and living spaces must be ventilated at least to the minimum specified in HUD standards.

FLASHING

- In areas where the bottom drip edge of the siding is adjacent to flashing, provide a minimum 3/8 in. gap between bottom drip edge of the siding and the flashing (see Fig. 8).
- Install flashing in a manner that creates proper out-sloping (see Fig. 8).
- Kick out flashing is required in areas where the roof and gutters are adjacent to the siding. Provide a 1 in. clearance between the gutter end and the siding (see Fig. 9).

INSTALLING

- Unless being applied above other siding, as in a gable area, a shim and starter strip are required. Start application by nailing a shim approximately 1-1/2 in. wide and 1/8 to 1/4 in. thick level with the bottom edge of the foundation sill plate.
- Starter strip should be 4-5 in. wide, 1/2 in. thick and installed to hang below shim approximately 1 in. (see Fig. 5). If desired, the starter strip can be cut from the top of the siding and the bottom portion used for the top course.
- The indentations (profile cut outs) of the bottom edge of the first course of siding must overlap the starter strip at least 1 in.
- The indentations (profile cut outs) of the bottom edge of each successive course of siding must overlap the siding below at least 1 in.
- Place nails 5/8 in. to 3/4 in. up from the drip edge. Make sure that drip edge nails penetrate both courses of siding and into studs (see Fig. 5).
- Periodic checks are necessary to ensure the horizontal lap remains level. Make adjustments as necessary.
- Vertical butt joints must be located only on studs.
- Stagger alternating courses one-half of the repeating pattern for design appeal. This may require trimming of one piece so that butt ends align with studs 16 in. o.c.
- Cut second course so ends fall on studs to provide a staggered appearance.

- When butting siding to inside or outside corners, use a minimum 1 in. thick dry wood material. TruWood Trim is recommended (see Fig. 4).
- Make sure to prime and paint all exposed cut edges.

FASTENING

- Use corrosion resistant boxhead nails with a minimum head diameter of 1/4 in. (10% variance allowed).
- Fastening must not exceed 16 in. o.c. (see Framing section for 24 in. o.c. stud spacing).
- All lap products require that the butt joints be located on the studs and nailed at the joints (see Fig. 2 and 3).
- Nails must penetrate wood framing 1-1/2 in. (see Fig. 1).
- Avoid countersinking nails or rupturing the surface of the siding. If countersinking occurs, seal nail prior to painting (see Fig. 1).
- Fasten from end to end or center to end to avoid internal stress.

GAPS AND CORNERS

- Leave 3/16 in. gap around all doors, window frames and corners. Seal all gaps (see Fig. 4).

BUTT JOINTS

- All butt joints must be located over studs.
- For Designer Shake Lap Siding, leave 3/16 in. gap at all butt joints (see Fig. 2).
- Seal all butt joints.

CLEARANCES

- Siding must have a minimum 2 in. separation from concrete or be appropriately flashed.
- Siding must be 6 in. from soil or landscaping material.

- Where the siding meets the roof, it must be spaced a minimum of 2 in. from the plane of the roof and be properly flashed. The cut edge must be primed and painted.
- Vegetation must not be in direct contact with the siding.

SEALING

- Use the best quality flexible, paintable, mildew-resistant exterior grade sealant material that meets ASTM C920, Class 25 or higher.
- Seal around all openings such as window and door frames and at butt joints.
- Seal all overdriven nails (see Fig. 1).
- Seal or flash all horizontal trim material in a manner that creates proper out-sloping.

PAINTING

- Touch up damaged areas with premium acrylic latex primer or premium alkyd oil-based primer.
- Siding must be finish-painted within 90 days after installation. If siding is exposed for a longer period, reprime the siding.
- Siding must be clean and dry when paint is applied.
- Use only premium acrylic latex paint or premium alkyd oil-based paint containing an appropriate amount of mildewcide for local moisture conditions.
- For best performance, use 100% acrylic latex paints or 100% acrylic latex solid body (opaque) stain.
- Follow paint manufacturer's recommendations for engineered wood siding.
- A minimum of 4 dry mils, which includes 1 mil factory primer, is required. This is best achieved with two coats of finished paint.
- Drip edges and grooves must be well coated.
- All surfaces and exposed cut edges must be painted in place.

PROPER STORAGE

- Store siding flat and support it on stringers to avoid sagging and contact with the ground.
- Siding must be covered and protected from the elements.
- Allow siding to acclimatize to local conditions prior to installation.

CONSTRUCTION ESSENTIALS

- The structure must be constructed to meet local applicable building requirements, HUD minimum property standards or HUD manufactured housing construction and safety standards. Lap siding does not provide shear strength.

WARRANTY REQUIREMENTS

- The terms of the Limited Warranty require strict compliance with the installation instructions. These instructions are supplemental to applicable local building codes and standard building practices. Compliance with the most stringent of these is required. Architectural designs, plans and specifications must comply with these instructions.
- All deviations from the installation instructions must be pre-approved in writing by the Collins Products LLC Product Performance Manager.

INSTALLATION ERRORS THAT VOID THE WARRANTY

- Do not apply siding to a rain soaked structure.
- Do not apply siding that is wet. Wet siding can shrink after application and shrinkage is not covered by the TruWood warranty.
- Wet blown insulation is not allowed.
- Do not apply stucco or composite stucco products over the siding.
- Do not apply the siding to floating structures or buildings over water.
- Staples are not an acceptable fastening device.
- Do not apply to wall systems without conventional framing.
- Do not bevel cut the siding edges at butt joints.
- Do not paint in wet or cold conditions.
- Do not use shake and shingle paints, low quality flat oil or alkyd paints, vinyl acetate (PVA), vinyl acrylic or vinyl acetate-acrylic co-polymer paints. These coatings do not adequately protect the siding.
- Do not blind nail siding.

Note: This list is not intended to be inclusive of all errors that would void the warranty. These are just some examples.

KEY HOMEOWNER MAINTENANCE RESPONSIBILITIES

- Inspect and renew all sealant and immediately repair any water penetration issues every year.
- Maintain gutters and downspouts to avoid water cascading down walls.
- Ensure sprinkler patterns are directed away from structures.
- Follow paint manufacturer's recommendations for repainting and paint maintenance.

CONDITION

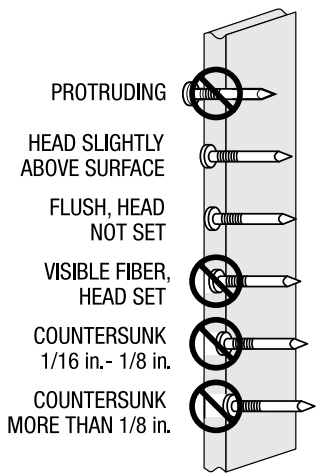

CORRECTION

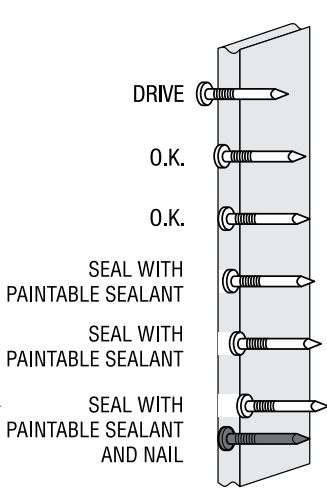

Figure 1

OLD MILL SHINGLE AND DESIGNER SHAKE NAILING

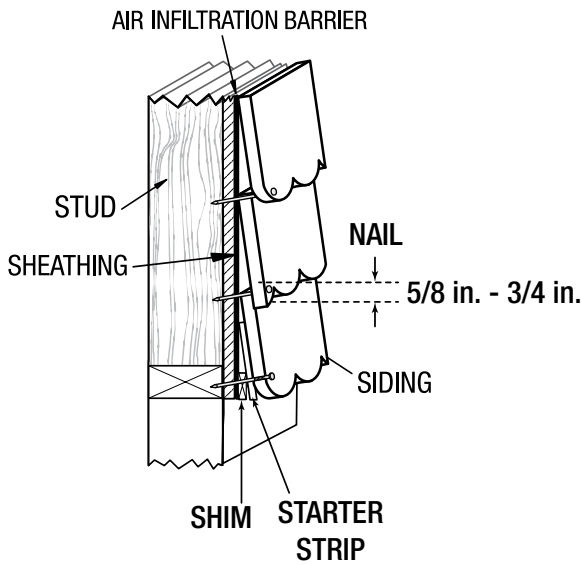

Figure 5

STAGGERED JOINTS

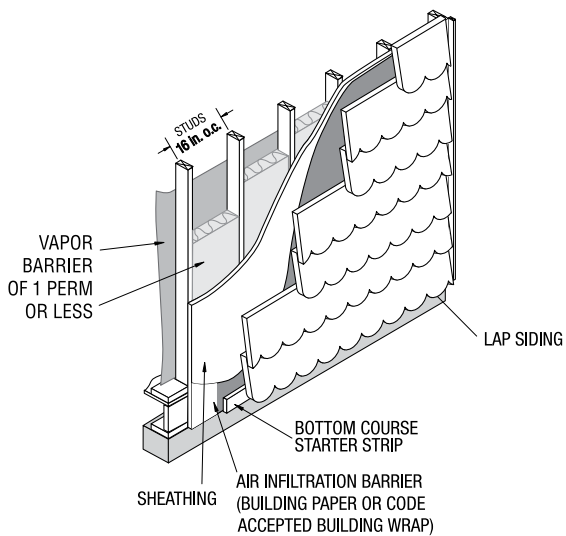

Figure 7

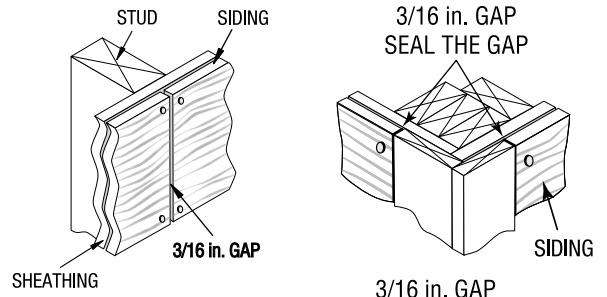

Figure 2

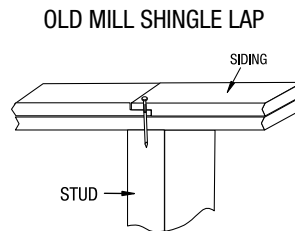

Figure 3

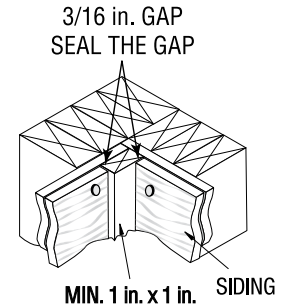
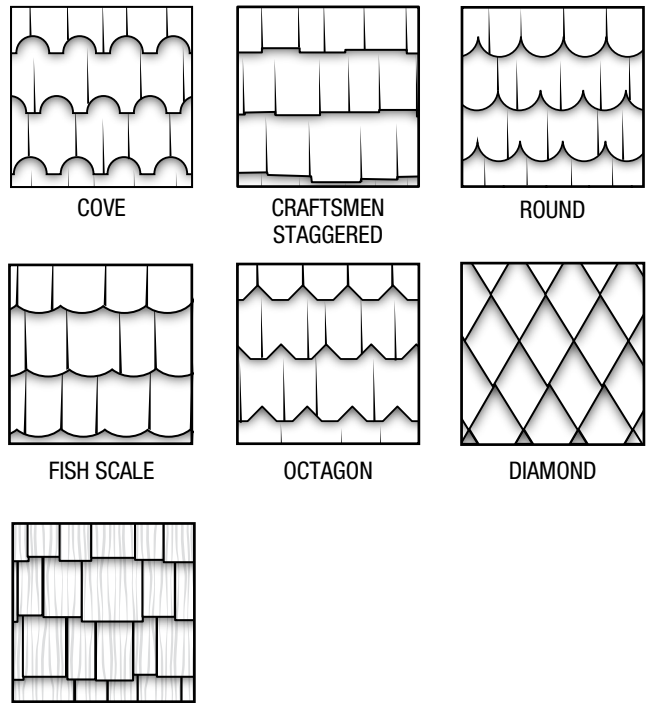

Figure 4

DESIGNER SHAKE STYLES



OLD MILL SHINGLE LAP

Figure 6

FLASHING

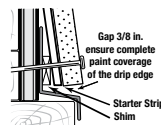
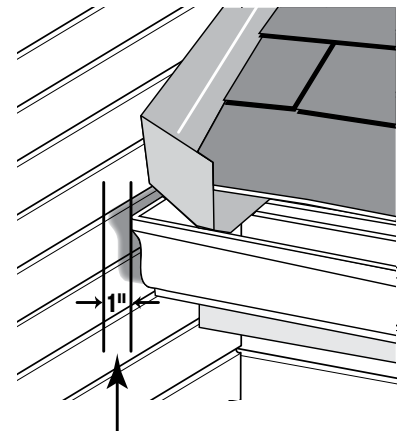

Figure 8



1 in. clearance between gutter end and siding

Figure 9

- Apply siding over approved structural sheathing.
- Maximum nail spacing is 16 in. on center.
- Nails must penetrate wood framing 1-1/2 in.
- Do not use staples. Use only the nails specified in these instructions.
- Install a minimum 3/16 in. gap at butt joints and ends. Use only approved methods to protect joints areas.
- Siding must not be in direct contact with stucco, mortar, stone, brick, concrete or masonry.
- Apply siding in a method that will prevent moisture entry into the siding or wall cavity.
- Seal all exposed cut ends using a method that will prevent moisture intrusion.
- Maintain the proper clearance from the siding bottom drip edge to the finished grade, walkways and adjacent to the roof lines.

CODES AND STANDARDS

TruWood® Siding meets the requirements of the following codes and standards:

- 2024 International Building Code
- 2024 International Residential Code
- ICC ESR-2588
- ANSI A135.6-2012 (R2020)
- Wildland-Urban Interface (WUI) Approved*

***WUI APPLICATION REQUIREMENTS**

- Framing must not exceed 16 in. on center.
- Minimum 5/8 in. Type-X gypsum exterior sheathing is required.

Installation Instructions **for Panel Siding, Soffit and Overhead Application**

7/16 in. Panels Include:

Sturdy Panel, Square Edge, 3/4 in. Channel
and Reverse Board and Batten (RB&B)

1/2 in. Panels Include:

Adobe Shiplap and 808

Important:

**Read and understand all pages of
the installation instructions before
starting the siding application.**

**For TruWood care and maintenance information,
warranty information, and installation videos,
visit our web site at: TruWoodSiding.com**

FRAMING

- Apply these panel siding products on walls and gables that meet racking requirements.
- Follow specific nailing pattern (see Fig. 6).
- Framing must not exceed 16 in. on center (o.c.).
- Although not recommended, where 24 in. o.c. vertical framing is used, nail to framing 24 in. o.c. with intermediate nailing 12 in. o.c. to sheathing with a 6d galvanized ring shank nail. This effectively creates a 12 in. o.c. nailing schedule.

SHEATHING

- Sheathing is required for all siding products. Recommended sheathing is a minimum of 7/16 in. OSB or 1/2 in. exterior grade plywood.
- Foam sheathing or other composite sheathing may be substituted. Collins Products LLC will not be responsible for problems related to crushing of the foam during or after siding applications, or moisture accumulation in the wall cavity.

VAPOR BARRIERS, VENTILATION AND MOISTURE CONTROL

- Roofs, gutters, roof to wall transitions, windows, doors, decks and attachments shall be designed, flashed and installed to prevent moisture entry into the siding or wall cavity or accumulation of water against the siding other than ambient moisture.
- Siding must have 2 in. clearance from masonry, concrete, brick, stone, stucco or mortar, or be properly flashed (see Fig. 7).
- A continuous vapor barrier rated 1 perm or less is required across the interior side of all walls to be sided.
- A vapor barrier rated 1 perm or less must be installed between the wood sill, wood framing and the foundation wall.
- A vapor barrier ground cover must be used in crawl spaces.
- Crawl spaces, attics and living spaces must be ventilated at least to the minimum specified in HUD standards.

FLASHING

- In areas where the bottom drip edge of the siding is adjacent to flashing, provide a minimum 3/8 in. gap between bottom drip edge of the siding and the flashing (see Fig. 7).
- Install flashing in a manner that creates proper out-sloping (see Fig. 7).
- Kick out flashing is required in areas where the roof and gutters are adjacent to the siding. Provide a 1 in. clearance between the gutter end and the siding (see Fig. 8).

INSTALLING

- Examine the framed structure to determine the positioning of the studs in relation to the exterior corners, windows and openings. Plan for areas that do not allow for installation of full panels.
- From your pre-selected starting position, place a panel square on the wall with the bottom edge level. All side edges must be positioned over studs. All horizontal edges must be positioned over framing. When positioning the next panel, do not force the panel into place. If installing a shiplap panel, place overlap edge on top of the underlap edge prior to nailing.
- At corners, use TruWood Trim (see Fig. 3).
- Follow fastening schedule (see Fig. 6).

FASTENING

- Use corrosion resistant boxhead nails with a minimum head diameter of 1/4 in. (10% variance allowed).
- Fastening must not exceed 16 in. o.c. (see Framing section for 24 in. o.c. stud spacing).
- All siding joints must be located on studs (see Fig. 2).
- Nails must penetrate wood framing 1-1/2 in.
- Avoid countersinking nails or rupturing the surface of the siding. If countersinking occurs, seal nail prior to painting (see Fig. 1).
- Fasten from side to side or center side to avoid internal stress.
- Nailing schedule for soffit application of siding products must not exceed 16 in. o.c.

- For siding used as soffit material, the siding must be nailed 12 in. or 16 in. o.c. into the framing.

GAPS AND CORNERS

- For all shiplap edge panels, there should be a 1/16 in. gap between the underlap edge and the next panel. An alignment ridge helps with this placement. Do not force the edge of the panel over this ridge.
- For Adobe panels, the shiplap edge will be visible unless a batten strip is used to cover it.
- For square edge panels, there must be a 3/16 in. gap at the vertical joint (see Fig. 2). This gap must be sealed. It is recommended to cover the joint with a wood batten strip. TruWood Trim is recommended for batten material.
- Leave 3/16 in. gap around all doors, window frames and corners. Seal all gaps (see Fig. 2 and 3).

JOINTS

- All side edge joints must be located over studs.
- All horizontal joints must be located over framing.
- At horizontal joints with stacked panels or other types of siding, overlap siding 1 in. or use Z flashing and fasten as shown (see Fig. 4).

CLEARANCES

- Siding must have a minimum 2 in. separation from concrete or be appropriately flashed.
- Siding must be 6 in. from soil or landscaping material.
- Where the siding meets the roof, it must be spaced a minimum of 2 in. from the plane of the roof and be properly flashed. The cut edge must be primed and painted.
- Vegetation must not be in direct contact with the siding.

SEALING

- Use the best quality flexible, paintable, mildew-resistant exterior grade sealant material that meets ASTM C920, Class 25 or higher.
- Seal around all openings such as window and door frames and at butt joints.

- Seal all overdriven nails (see Fig. 1)
- Seal or flash all horizontal trim material in a manner that creates proper out-sloping.

PAINTING

- Touch up damaged areas with premium acrylic latex primer or premium alkyd oil-based primer.
- Siding must be finish-painted within 90 days after installation. If siding is exposed for a longer period, reprime the siding.
- Siding must be clean and dry when paint is applied.
- Use only premium acrylic latex paint or premium alkyd oil-based paint containing an appropriate amount of mildewcide for local moisture conditions.
- For best performance, use 100% acrylic latex paints or 100% acrylic latex solid body (opaque) stain.
- Follow paint manufacturer's recommendations for engineered wood siding.
- A minimum of 4 dry mils, which includes 1 mil factory primer, is required. This is best achieved with two coats of finished paint.
- Drip edges and grooves must be well coated.
- All surfaces and exposed cut edges must be painted in place.

When used as soffit and other overhead applications, it is acceptable to attach directly to framing without sheathing provided the following is followed:

GENERAL

- All other installation requirements are followed as outlined in the installation instructions.
- 3/16" gapping is maintained at all ends and edges.
- All cross framing and ladder framing must be attached to framing members.
- Center out nailing or one end to the other nailing. Do not tack corners and nail to the center.

SOFFIT

- 12" and 16" wide soffit: 6" on center perimeter nailing except on ends of panels. Use batten strip to cover butt joints.
- 24" soffit: 6" on center perimeter nailing. Must have cross framing at the butt joint. Batten strips to cover butt joints.
- Over 24" Soffit: 6" on center perimeter nailing. Must have cross framing at the butt joint. Ladder blocking 24" on center. Batten strips to cover butt joints.
- 12" on center nailing on interior framing members.

OVERHEAD APPLICATION

- 6" on center perimeter nailing on ends and edges of panels. Use batten strip to cover butt joints.
- Cross framing cannot exceed 24" on center. Batten strips to cover butt joints.
- 12" on center nailing on interior framing members.

PROPER STORAGE

- Store siding flat and support it on stringers to avoid sagging and contact with the ground.
- Siding must be covered and protected from the elements.
- Allow siding to acclimatize to local conditions prior to installation.

CONSTRUCTION ESSENTIALS

- The structure must be constructed to meet local applicable building requirements, HUD minimum property standards or HUD manufactured housing construction and safety standards. Panel siding does not provide shear strength.

WARRANTY REQUIREMENTS

- The terms of the Limited Warranty require strict compliance with the installation instructions. These instructions are supplemental to applicable local building codes and standard building practices. Compliance with the most stringent of these is required. Architectural

designs, plans and specifications must comply with these instructions.

- All deviations from the installation instructions must be pre-approved in writing by the Collins Products LLC Product Performance Manager.

INSTALLATION ERRORS THAT VOID THE WARRANTY

- Do not apply siding to a rain soaked structure.
- Do not apply siding that is wet. Wet siding can shrink after application and shrinkage is not covered by the TruWood warranty.
- Wet blown insulation is not allowed.
- Do not apply stucco or composite stucco products over the siding.
- Do not apply the siding to floating structures or buildings over water.
- Staples are not an acceptable fastening device.
- Do not apply to wall systems without conventional framing.
- Do not bevel cut the siding edges at butt joints.
- Do not paint in wet or cold conditions.
- Do not use shake and shingle paints, low quality flat oil or alkyd paints, vinyl acetate (PVA), vinyl acrylic or vinyl acetate-acrylic co-polymer paints. These coatings do not adequately protect the siding.
- Do not blind nail siding.

Note: This list is not intended to be inclusive of all errors that would void the warranty. These are just some examples.

KEY HOMEOWNER MAINTENANCE RESPONSIBILITIES

- Inspect and renew all sealant and immediately repair any water penetration issues every year.
- Maintain gutters and downspouts to avoid water cascading down walls.
- Ensure sprinkler patterns are directed away from structures.
- Follow paint manufacturer's recommendations for repainting and paint maintenance.

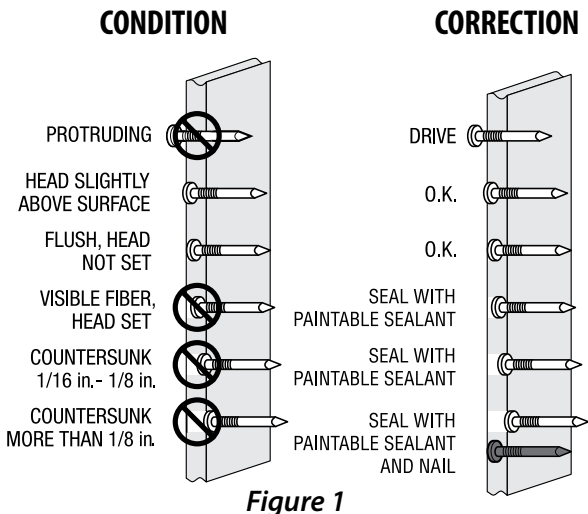

Figure 1

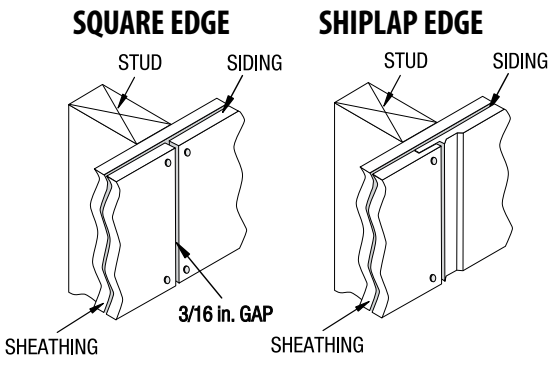

Figure 2

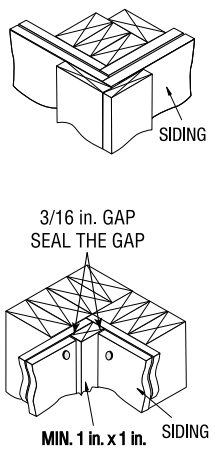

Figure 3

HORIZONTAL JOINT DETAIL

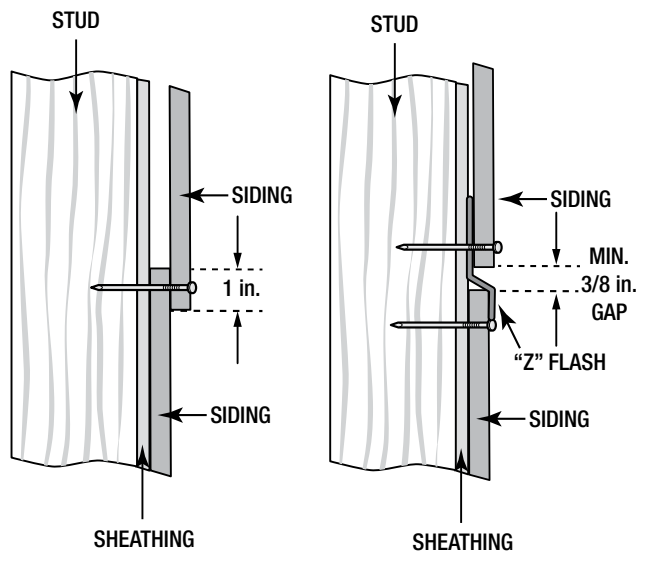

Figure 4

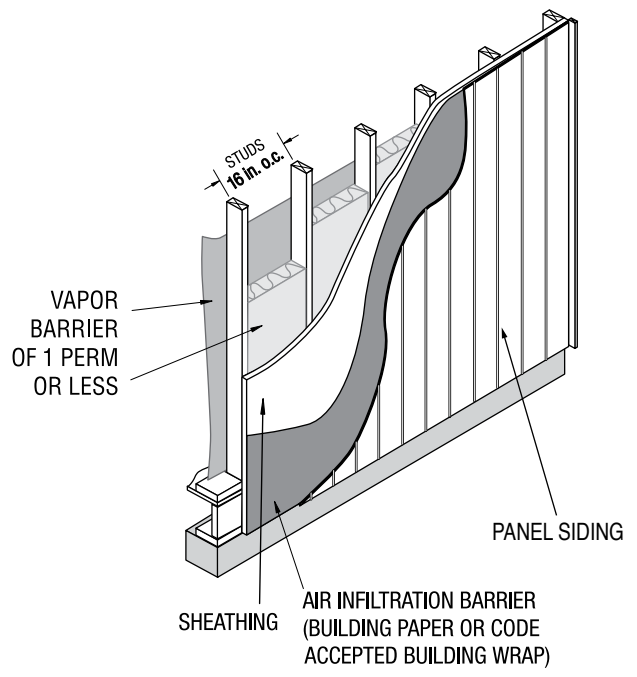

Figure 5

| FASTENING SCHEDULE | | | |
|--------------------|----------------|--|--|
| SIDING | HOW TO APPLY | EDGE NAILING LOCATION | NAILING SCHEDULE |
| Square Edge Panel | Over sheathing | 3/8 in. - 1/2 in. vertical 1/2 in. - 2 in. horizontal | 6 in. o.c. edges 12 in. o.c. intermediate |
| Shiplap Edge Panel | Over sheathing | 1/2 in. - 5/8 in. vertical 1/2 in. - 2 in. horizontal | 6 in. o.c. edges 12 in. o.c. intermediate |

Figure 6

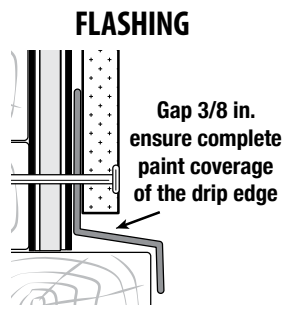

Figure 7

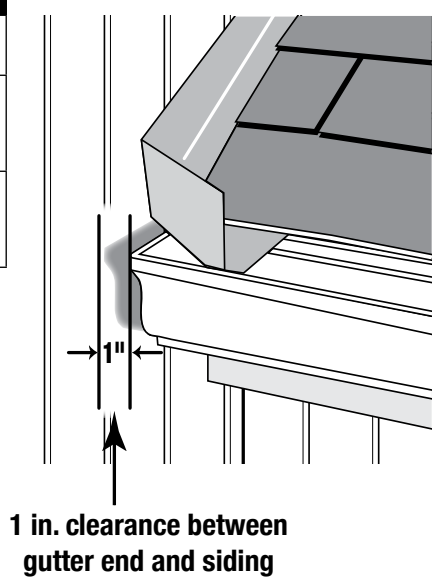

Figure 8

- Apply siding over approved structural sheathing.
- Maximum nail spacing is 16 in. on center.
- Nails must penetrate wood framing 1-1/2 in.
- Do not use staples. Use only the nails specified in these instructions.
- Install a minimum 3/16 in. gap at butt joints and ends. Use only approved methods to protect joints areas.
- Siding must not be in direct contact with stucco, mortar, stone, brick, concrete or masonry.
- Apply siding in a method that will prevent moisture entry into the siding or wall cavity.
- Seal all exposed cut ends using a method that will prevent moisture intrusion.
- Maintain the proper clearance from the siding bottom drip edge to the finished grade, walkways and adjacent to the roof lines.

CODES AND STANDARDS

TruWood® Siding meets the requirements of the following codes and standards:

- 2024 International Building Code
- 2024 International Residential Code
- ICC ESR-2588
- ANSI A135.6-2012 (R2020)
- Wildland-Urban Interface (WUI) Approved*

***WUI APPLICATION REQUIREMENTS**

- Framing must not exceed 16 in. on center.
- Minimum 5/8 in. Type-X gypsum exterior sheathing is required.



**Warranty, Care,
and Maintenance Information**

30-YEAR LIMITED WARRANTY TRUWOOD SIDING & TRIM

1. LIMITED WARRANTY – TRANSFERABLE WARRANTY COVERAGE

THIS LIMITED WARRANTY IS SUBJECT TO THE LIMITATIONS AND RESTRICTIONS DESCRIBED IN SECTIONS 3 AND 4 BELOW.

Collins Products (“Collins”) warrants that its TruWood Siding & Trim products (the “Products”) were manufactured to meet or exceed the specifications set forth in ANSITruWoodSA 135.6. Collins warrants its Products, exclusive of factory applied coatings, against defects in material, workmanship and buckling (defined as more than 1/4 in. deflection between studs installed at 16 in. on center) of the basic structure for a period of 30 years from the date of installation (“Product Warranty Period”) as long as the Products have been stored, handled, installed, finished, and maintained in accordance with TruWood installation instructions and care and maintenance recommendations in effect at the time of installation (“Collins Instructions”). Collins further warrants the factory-applied primed coatings (the “Coatings”), exclusive of the Products, against defects in material and chipping, peeling and blistering for 5 years from the date of installation as long as the Products have been stored, handled, installed, finished, and maintained in accordance with Collins Instructions. This Warranty is transferable from the purchaser of the Products to the owner of the structure on which the Products are installed, if purchaser and structure owner are not one and the same. The Warranty is further transferable from the owner of the structure on which the Products are installed to the first subsequent owner of the same structure (collectively, the “Owner”). The Warranty is not transferable to any subsequent structure owner.

2. WARRANTY REMEDIES

THIS SECTION PROVIDES THE SOLE AND EXCLUSIVE REMEDY AVAILABLE TO ANY OWNER.

If any Product or Coating fails to perform as warranted (or fails to perform in accordance with any implied warranty not disclaimed herein), during the first five years from the date of installation, at its option, Collins will either (i) provide labor and materials necessary to replace the defective Products or (ii) reimburse Owner for any replacement costs in an amount up to two (2) times the original purchase price of the Products, less any replacement costs directly attributable to Owner’s failure to follow Collins Instructions (“Maximum Reimbursement”). Starting in the 6th year following original installation of the Products, Maximum Reimbursement for replacement costs will be reduced by 4% per year, such that from and after the 30th year, Maximum Reimbursement payable under this warranty will be zero.

In connection with any dispute under this Section, Owner shall have the burden of proof that the Product has been stored, handled, installed, finished, and maintained according to Collins Instructions. Notwithstanding anything to the contrary herein, as an express condition of this Warranty, prior to undertaking any repair or replacement of any affected Products and prior to exercising any rights set forth in Section 5, Owner must (i) notify Collins, in writing, within 60 days of first discovering the condition, at the address in Section 6 and provide annotated photographs, and (ii) allow Collins a reasonable period of time to inspect and/or investigate the condition of the Products in question. Subject to the foregoing, all claims under this Warranty must nonetheless be submitted to Collins in writing within 30 years and 60 days of the date of installation.

3. WARRANTY LIMITATIONS

ANY EXPRESS OR IMPLIED WARRANTIES ARE LIMITED TO THE DURATION OF THE LIMITED WARRANTY. SOME STATES DO NOT ALLOW LIMITATIONS ON HOW LONG AN IMPLIED WARRANTY LASTS, SO THE ABOVE LIMITATION MAY NOT APPLY TO YOU. NO COLLINS RESELLER, AGENT, DISTRIBUTOR, SUPPLIER OR EMPLOYEE IS AUTHORIZED TO MAKE ANY MODIFICATION, EXTENSION OR ADDITION TO THIS WARRANTY.

This Warranty does not cover damage to Products due to: (i) misuse, abuse or improper transportation, storage, handling, installation, painting, refinishing, or maintenance; (ii) alterations to the structure after the original installation of Products; (iii) design, application, or construction of the structure on which Products are installed; (iv) failure to comply with applicable building codes and accepted building practices; (v) use or application of sawed or “ripped” TruWood siding as trim; (vi) prolonged contact with accumulated water due to wall, roof, door, window, deck or any other water infiltration leaks, ineffective vapor barriers or failure to maintain Products; (vii) performance of any field-applied finishes; (viii) mold, mildew or fungus; (ix) performance of Products installed on any structure located outside the United States of America; (x) acts of God, war, civil disorder, hurricane, tornado, hail, earthquake, flood, fire, lightning, mudslide, air pollution, severe weather or any other similar cause beyond the control of Collins, or (xi) any condition referenced in the Collins Instructions “Installation Errors That Void the Warranty;” (xii) swelling and/or edge checking (such swelling and/or edge checking normally occurs in all wood products as they expand and contract in response to changes in climatic conditions). This Warranty requires strict compliance with Collins Instructions. Collins is not responsible for any damages caused by any other party.

4. EXCLUSION OF INCIDENTAL OR CONSEQUENTIAL DAMAGES

COLLINS IS NOT RESPONSIBLE FOR DIRECT, SPECIAL, INCIDENTAL OR CONSEQUENTIAL DAMAGES RESULTING FROM ANY BREACH OF WARRANTY OR CONDITION, OR UNDER ANY OTHER LEGAL THEORY INCLUDING, WITHOUT LIMITATION, PROPERTY DAMAGE, LOST PROFITS, LOSS OF USE, OR OTHER ECONOMIC LOSS. SOME STATES DO NOT ALLOW THE EXCLUSION OR LIMITATION OF INCIDENTAL OR CONSEQUENTIAL DAMAGES, SO THE ABOVE LIMITATION OR EXCLUSION MAY NOT APPLY TO YOU.

5. ADDITIONAL EXCLUSIONS

TruWood ValuForm (concrete forming products) is not warranted for use as exterior siding.

Any TruWood Siding & Trim products shipped and installed outside of the U.S.A. are not warranted.

6. STATE LAW

This warranty gives you specific legal rights, and you may also have other rights which vary from state to state.

7. CONTACT US

To receive Product information bulletins and other information concerning the proper installation, use and/or maintenance of the Products, please contact Collins at: **800.329.1219**. For inquiries regarding Warranty service, claims, or technical services, contact Collins at **800.417.3674**. To submit a claim, send written notice of such claim, including annotated photographs, by certified mail, to Collins, 29100 SW Town Center Loop West, Suite 300, Wilsonville, OR 97070-9315, USA, addressed to the attention of “TruWood Warranty Service.” For sales, contact TruWoodSiding.com.

Manufactured by:
Collins Products LLC
29100 SW Town Center Loop West, Suite 300
Wilsonville, OR 97070-9315 USA
TruWoodSiding.com

CARE AND MAINTENANCE

GENERAL: The suggestions and recommendations below should be followed to achieve satisfactory performance of any TruWood Product. Failure to comply may result in a reduced useful life of the Product and void the Product warranty.

INSPECTION: The Product should be inspected periodically in accordance with the following maintenance items: (i) re-nail loose Product; (ii) trim trees and bushes that are in contact with the Product; (iii) replace caulking that has hardened, cracked and/or lost its seal; (iv) correct grade drainage where retained water is in contact with the Product; (v) eliminate overspray from lawn and landscaping sprinklers; (vi) check the condition of Coating as set forth below; (vii) follow any applicable paint manufacturer's repainting recommendations; and (viii) maintain gutters and downspouts. (See TruWood Instructions "Key Homeowner Maintenance Responsibilities".)

REFINISHING: Exterior wall finishes weather most rapidly on those portions of the building that receive the greatest exposure to sun and moisture. Areas receiving maximum exposure may require refinishing as often as every 3 years. The frequency of refinish will depend on geographic locations; the type, quality and color of the paint; and on other factors such as the method of paint application and the number of coats. Repainting is dictated by the degree of wear or erosion of the old paint. Refinishing is typically required if the Product is discolored and blotchy; if the Coating is cracked, peeling or scaling; or if the Coating appears thin, porous and chalked to a point where it no longer protects or hides the surface. Severe paint cracking, flaking or peeling is not normal paint weathering. Such problems may be caused by inferior paints, incompatible paints, improper painting procedures or by improper construction that permits water or water vapor to reach, condense, or freeze on the back side of the Product. (See TruWood Instructions "Painting".)

Frequent repainting can result in excessive total paint film thickness, which may cause problems such as cracking and pooling. On the other hand, unreasonable delays in maintenance repainting may contribute to deterioration of both the paint and Product such that refinishing cannot be accomplished effectively. In general, it is recommended that the total Coating film thickness be maintained at 4 dry mils. This typically is considered the equivalent of three coats of finish (one coat of primer plus two coats of finish paint).

SURFACE PREPARATION: The extent of surface preparation is dependent on the condition of the old finish. Loose paint material should be removed. The surface should be washed and all mildew must be removed before painting. Use of a power washer is not recommended. (See TruWood Instructions "Key Homeowner Maintenance Responsibilities" and "Painting".)

REPRIMING: If the old surface is sound (no peeling, cracking, heavy caulking, etc.), repriming is typically not necessary unless it is recommended by the paint manufacturer for the top coat chosen. If the Product's base substrate and/or if the old primer is exposed, these areas should be reprimed. If the Product's edges or ends show any cracks or fissures, these should be resealed with a primer. (Only premium exterior oil/alkyd type primers or premium acrylic latex primers are recommended.) The primer used must be compatible with the chosen top coat and the primer manufacturer recommendations followed in all respects. (See TruWood Instructions "Painting".)

SELECTING AND APPLYING FINISH COAT PAINTS/STAINS: These recommendations deal with refinish over field-applied finish coats. A premium paint that is suitable for use on hardboard siding must be used. The finish chosen should be compatible with the existing old finish. Only premium exterior acrylic latex paints are recommended when finish is applied to textured products. Satin or gloss oil/alkyd paints are also acceptable, as are opaque acrylic latex stains. The following finish coats (paints/stains) are not recommended: shake and shingle paints, flat alkyd oil-based paints and stains, vinyl acetate (PVA), vinyl/acrylic or vinyl/acetate/acrylic copolymer paints and stains, semi-transparent stains, clear coatings. The finish coat of paint or stain should be applied in strict accordance with the recommendations of the paint manufacturer. (See TruWood Instructions "Painting".) Exception: for smooth TruWood products, use only premium alkyd oil-based paint.

MILDEW: Mildew, mold and other fungus growths must be removed from the Product particularly before repainting the Product. This may be accomplished by scrubbing the infected surface thoroughly with mildew removal products or the following solution:

- 2/3 cup TSP (trisodium phosphate) – available in paint or hardware stores
- 1/3 cup detergent containing no ammonia (Tide or an equivalent)
- 1 quart 5% sodium hypochlorite (Clorox or an equivalent)
- 3 quarts warm water or enough to make one gallon

Protective hand and eyewear must be worn when applying any removal product or the solution. The Product should be scrubbed with a soft brush and then rinsed thoroughly with fresh water. Do not place or splash the solution on landscaping. Promptly after the Product has been cleaned and has dried, a mildew resistant paint should be applied.

CONTACT US

To receive Warranty information, Product information bulletins and other information concerning the proper installation, use and/or maintenance of your Product, please contact TruWood at:

Warranty Inquiries, Claims, Technical Services & Marketing: **800.329.1219** • Sales: **800.417.3674** • TruWoodSiding.com

Manufactured by:

Collins Products LLC

29100 SW Town Center Loop West, Suite 300

Wilsonville, OR 97070-9315 USA

TruWoodSiding.com

ICC-ES Evaluation Report

ESR-2588

Reissued June 2024

This report also contains:

Revised June 21, 2024

- CBC Supplement

Subject to renewal June 2026

ICC-ES Evaluation Reports are not to be construed as representing aesthetics or any other attributes not specifically addressed, nor are they to be construed as an endorsement of the subject of the report or a recommendation for its use. There is no warranty by ICC Evaluation Service, LLC, express or implied, as to any finding or other matter in this report, or as to any product covered by the report.

Copyright © 2024 ICC Evaluation Service, LLC. All rights reserved.

| | | | |
|---|--|--|---|
| <p>DIVISION: 07 00 00— THERMAL AND MOISTURE PROTECTION</p> <p>Section: 07 46 00— Siding</p> | <p>REPORT HOLDER:</p> <p>COLLINS PRODUCTS, LLC</p> | <p>EVALUATION SUBJECT:</p> <p>TRUWOOD® LAP AND PANEL SIDING PRODUCTS</p> |  |
|---|--|--|---|

1.0 EVALUATION SCOPE

Compliance with the following codes:

- 2024, 2021, 2018, 2015, 2012, and 2009 [International Building Code® \(IBC\)](#)
- 2024, 2021, 2018, 2015, 2012, and 2009 [International Residential Code® \(IRC\)](#)
- Other Codes (see Section 8.0)

Properties evaluated:

- Exterior wall covering
- Wall bracing

2.0 USES

TruWood® lap and panel sidings are used as exterior wall covering materials for buildings permitted to be of Type V-B construction and for structures constructed in accordance with the IRC. The TruWood® lap and panel sidings are hardboard sidings complying with 2024, 2021 and 2018 IBC Sections 1403.3.2 and 2303.1.7, 2015 IBC Sections 1404.3.2 and 2303.1.7, 2012 and 2009 IBC Sections 1404.3.2 and 2303.1.6 and 2024, 2021 and 2018 IRC Table R703.3.2, 2015 IRC Table R703.3(1), 2012 and 2009 IRC Table R703.4. The panel siding is also used for conventional light-frame wood construction as braced wall panels within designated braced wall lines as defined in 2024 IBC Section 2308.10, 2021, 2018 and 2015 IBC Section 2308.6, 2012 and 2009 IBC Section 2308.3 and IRC Section R602.10.1.

3.0 DESCRIPTION

TruWood® lap and panel siding products are fibrous-felted hardboard panels made from either non-zinc borate treated wood fiber or zinc borate treated wood fiber that is consolidated under heat and pressure to a uniform density. The product is manufactured in 7/16-inch [0.400 inch (10.2 mm) actual] and 1/2-inch [0.490 inch (12.5 mm) actual] thicknesses and has a factory-applied primer on one face. The product is produced in lap siding and panel configurations having a variety of smooth or embossed surface patterns. TruWood® lap siding products are machined to a variety of groove patterns, lengths, ranging from 48 inches to 192 inches (1219 to 4877 mm), and widths, ranging from 6 inches to 16 inches (152 to 406 mm). TruWood® panel siding products are machined to a variety of groove patterns, lengths, ranging from 48 inches to 192 inches (1219 to 4877 mm), and widths, ranging from 47 inches to 50 inches (1193 to 1270 mm). TruWood® siding complies with CPA/ANSI A135.6.

Lap siding is available with square or beveled edges, or with a self-aligning feature on the back of each piece to allow for alignment of subsequent courses. Premium lap siding has horizontal shiplap joints. Sure Lock Lap

Siding with Concealed Nailing System has tongue-and-groove joints on each piece. Panel siding is available with squared edges on all four edges or with square horizontal edges and shiplap vertical edges.

4.0 DESIGN AND INSTALLATION

4.1 General:

Installation of TruWood® siding must comply with this report and the manufacturer's published installation instructions. The manufacturer's published installation instructions must be available at the jobsite at all times during installation.

Except where otherwise noted in this report, installation must comply with 2024 IBC Table 2308.10.3(5), 2021, 2018 and 2015 IBC Table 2308.6.3(5), 2012 and 2009 IBC Table 2308.9.3(5), 2024, 2021 and 2018 IRC Table R703.3.2, 2015 IRC Table R703.3.(1), or 2012 and 2009 IRC Table R703.4, as applicable. A water-resistive barrier in accordance with IBC Section 1403.2 or IRC Section R703.2 must be applied directly beneath the siding. Vertical butt joints of the siding must occur over framing members. A $\frac{3}{16}$ -inch (4.8 mm) gap must be provided at all joints and around all openings. Gaps and vertical end joints must be caulked with an approved sealant. A minimum 6-inch (152 mm) clearance is required from the bottom of the siding to adjacent grade. Siding must not be in direct contact with concrete. All exterior openings must be flashed in accordance with the applicable code. Fasteners used to attach the siding material to pressure-preservative-treated wood must be zinc-coated in accordance with ASTM A153.

4.2 Lap Siding:

All siding courses must be lapped a minimum of 1 inch (25.4 mm) unless self-aligning or tongue-and-groove joints are provided on the siding. Sixteen-inch-wide (406 mm) Premium lap siding requires three nails per lap siding board on all studs. Successive boards are nailed $\frac{5}{8}$ to $\frac{3}{4}$ inch (15.9 to 19.1 mm) up from the drip edge and in the center of the board. Sure Lock lap siding is nailed on the scribed top edge and locked into the siding piece below it.

4.3 Panel Siding:

Vertical edges of siding with shiplap edges must occur over framing. Vertical edges of square edged siding must occur over framing and should be covered with batten strips.

4.4 Panel Siding Used as Wall Bracing:

TruWood® panel siding with a minimum 48-inch (1219 mm) width as described in this report may be used as wall bracing in accordance with the HPS method in 2024 IBC Section 2308.10.3, 2021, 2018 and 2015 IBC Section 2308.6.4, the method number 8 in 2012 and 2009 IBC Section 2308.9.3, 2024, 2021, 2018, 2015 and 2012 IRC Section R602.10.5.2, and 2009 IRC Section R602.10.3.

4.5 Design:

The siding products are limited to use on structures of conventional light-frame wood construction under the 2024, 2021, 2018 and 2015 in areas where the basic wind speed (3-second gust), V , do not exceed 130 miles per hour (57 m/s), 2012 IBC in areas where wind speeds (3-second gust), V_{asd} , do not exceed 100 miles per hour [44 m/s (80 miles per hour (36 m/s) fastest mile)], or under the 2009 IBC in areas where wind speeds (three-second gust) do not exceed 100 miles per hour [44 m/s (80 miles per hour (36 m/s) fastest mile)]. In areas utilizing the IRC, the siding products are limited to use on structures in areas where wind speeds (3-second gust) are less than 110 miles per hour [48.4 m/s (90 miles per hour (40 m/s) fastest mile)]. The panel siding products are limited to use in Seismic Design Categories A, B or C, when they are used to resist seismic loads.

4.6 Finishing:

The primed siding must be cleaned, dried and finish-painted in accordance with the manufacturer's published installation instructions.

5.0 CONDITIONS OF USE:

The TruWood® siding products described in this report comply with, or are suitable alternatives to what is specified in, those codes listed in Section 1.0 of this report, subject to the following conditions:

- 5.1 Installation must comply with this report, the manufacturer's published installation instructions and the applicable code. In the event of a conflict between the manufacturer's published installation instructions and this report, this report governs.
- 5.2 All windows, doors and other exterior openings must be flashed in accordance with the applicable code. Horizontal joints between siding panels must be flashed and sealed in accordance with the manufacturer's instructions.

- 5.3 The siding products are limited to use on structures as described in Section 4.5.
- 5.4 The sidings must be installed over a water-resistive barrier in accordance with the applicable code.
- 5.5 TruWood® panel siding used to meet the bracing requirements of the HPS method in 2024 IBC Section 2308.10.4, 2021, 2018 and 2015 IBC Section 2308.6.4, the method number 8 in 2012 and 2009 IBC Section 2308.9.3, 2024, 2021, 2018, 2015 and 2012 IRC Section R602.10.5.2, and 2009 IRC Section R602.10.3 must comply with Section 4.4.
- 5.6 TruWood® siding products are produced in Klamath Falls, Oregon, under a quality-control program with inspections by ICC-ES.

6.0 EVIDENCE SUBMITTED

- 6.1 Manufacturer’s published installation instructions and product literature.
- 6.2 Reports of tests in accordance with CPA/ANSI A135.6.
- 6.3 Reports of racking resistance tests in accordance with ASTM E72.
- 6.4 Quality control documentation.

7.0 IDENTIFICATION

- 7.1 The ICC-ES mark of conformity, electronic labeling, or the evaluation report number (ICC-ES ESR-2588), along with the name (Collins Product, LLC), registered trademark, or registered logo of the report holder must be included in the product label.
- 7.2 In addition, each package containing the TruWood® siding products described in this report is identified by a stamp bearing the product name, the address of the manufacturing plant and the date of manufacture. Additionally, each package must bear a note indicating conformance to CPA/ANSI_A135.6.
- 7.3 The report holder’s contact information is the following:

COLLINS PRODUCTS, LLC
6410 HIGHWAY 66
KLAMATH FALLS, OREGON 97601
(541) 885-3303
<http://TruWoodSiding.com>
icronin@collinsco.com

8.0 OTHER CODES

8.1 Evaluation Scope:

The products in this report were also evaluated for compliance with the requirements of the 1997 *Uniform Building Code*™ (UBC).

8.2 Uses:

See Section 2.0, except TruWood® siding is for buildings permitted to be of Type V-N construction. Use of the shiplap panels for shear resistance is as noted in Section 8.4.

8.3 Description:

See Section 3.0.

8.4 Installation and Design:

See Section 4.0, except for the following:

TruWood® panel siding with a minimum 48-inch (1219 mm) width as described in this report may be used as wall bracing in accordance with method number 8 in UBC Section 2320.11.3. TruWood® siding products are limited to use on structures of conventional light-frame wood construction in areas where the basic wind speed (fastest mile) does not exceed 80 miles per hour (161 km/h). When TruWood® Shiplap Panel siding is installed in accordance with UBC Section 2310.6 and Table 23-II-C, the allowable racking shear design values must be as given in the following table.

| PANEL THICKNESS (inch) | DESIGN LOAD (lb./ft.) ¹ |
|---------------------------|---------------------------------------|
| 7/16 | 155 |
| 1/2 | 202 |

For SI: 1 inch = 25.4 mm, 1 lb./ft. = 14.59 N/m.
¹Values obtained on aged samples at 1/8-inch deflection.

8.5 Conditions of Use:

See Section 5.0, except for the following:

TruWood® siding panels used to meet the bracing requirements of method number 8 in UBC Section 2320.11.3 must comply with Section 8.4.

8.6 Evidence Submitted:

See Section 6.0.

8.7 Identification:

See Section 7.0

DIVISION: 07 00 00—THERMAL AND MOISTURE PROTECTION

Section: 07 46 00—Siding

REPORT HOLDER:

COLLINS PRODUCTS, LLC

EVALUATION SUBJECT:

TRUWOOD™ LAP AND PANEL SIDING PRODUCTS

1.0 REPORT PURPOSE AND SCOPE

Purpose:

The purpose of this evaluation report supplement is to indicate that TruWood™ lap and panel sidings, described in ICC-ES evaluation report ESR-2588, have also been evaluated for compliance with the codes noted below.

Applicable code editions:

- 2022 California Building Code (CBC)

For evaluation of applicable chapters adopted by the California Office of Statewide Health Planning and Development (OSHPD) AKA: California Department of Health Care Access and Information (HCAI) and the Division of the State Architect (DSA), see Sections 2.1.1 and 2.1.2 below.

- 2022 California Residential Code (CRC)

2.0 CONCLUSIONS

2.1 CBC:

The TruWood™ lap and panel sidings, described in Sections 2.0 through 7.0 of the evaluation report ESR-2588, comply with CBC Chapters 14 and 23, provided the design and installation are in accordance with the 2021 *International Building Code*® (IBC) provisions noted in the evaluation report ESR-2588 and the additional requirements of CBC Chapters 14 and 23, as applicable.

The TruWood™ lap and panel sidings has not been evaluated under CBC Chapter 7A for use in construction of exterior walls of new buildings located in any Fire Hazard Severity Zone within State Responsibility Areas or any Wildland–Urban Interface Area.

2.1.1 OSHPD:

The applicable OSHPD Sections and Chapters of the CBC are beyond the scope of this evaluation report supplement.

2.1.2 DSA:

The applicable DSA Sections and Chapters of the CBC are beyond the scope of this evaluation report supplement.

2.2 CRC:

The TruWood™ lap and panel sidings, described in Sections 2.0 through 7.0 of the evaluation report ESR-2588 comply with CRC Sections R602 and R703, provided the design and installation are in accordance with the 2021 *International Residential Code*® (IRC) provisions noted in the evaluation report ESR-2588 and the applicable provisions of the CRC.

The TruWood™ lap and panel sidings, described in this evaluation report supplement, has not been evaluated under CRC Section R337 for use in construction of exterior walls of new buildings located in any Fire Hazard Severity Zone within State Responsibility Areas or any Wildland–Urban Interface Area.

The TruWood™ lap and panel sidings described in this evaluation report supplement have not been evaluated for compliance with the *International Wildland–Urban Interface Code*®.

This evaluation report supplement expires concurrently with the evaluation report ESR-2588 reissued June 2024 and revised June 19, 2024.



**CALIFORNIA DEPARTMENT OF FORESTRY & FIRE PROTECTION
OFFICE OF THE STATE FIRE MARSHAL
FIRE ENGINEERING & INVESTIGATIONS DIVISION
BUILDING MATERIALS LISTING PROGRAM**

LISTING SERVICE

| | |
|----------------------|---|
| LISTING No.: | 8140-2025:0006 |
| CATEGORY: | 8140 - EXTERIOR WALL SIDING AND SHEATHING FOR WILDLAND URBAN INTERFACE (W.U.I) |
| LISTEE: | COLLINS PRODUCTS, LLC 6410 Highway 66, Klamath Falls, OR, 97601 Contact: Cronin, Jeff (541) 885-3303 (541) 885-3285 Email: jcronin@collinsco.com |
| DESIGN: | TruWood®7/16" Panel Siding, TruWood®1/2" Panel Siding, TruWood®7/16" Lap Siding, and TruWood®1/2" Lap Siding. All siding shall be installed over 5/8" Type X gypsum wallboard. Refer to the manufacturer's installation instructions and product data sheets. |
| RATING: | Compliance in accordance with Chapter 7A of the California Building Code. |
| INSTALLATION: | In accordance with listee's printed installation instructions, applicable codes and ordinances and in a manner acceptable to the authority having jurisdiction. |
| MARKING: | Listee name. Model number, rating and SFM label |
| APPROVAL: | Listed as exterior siding for use in the Wildland Urban Interface areas when installed over 5/8" Type X gypsum wallboard. |
| NOTES: | |

02-06-13 gt



This listing is based upon technical data submitted by the applicant. OSFM Fire Engineering staff has reviewed the test results and/or other data but does not make an independent verification of any claims. This listing is not an endorsement or recommendation of the item listed. This listing should not be used to verify correct operational requirements or installation criteria. Refer to listee's data sheet, installation instructions and/or other suitable information sources.

Date Issued: 05/01/2024

Listing Expires: 06/30/2025

Authorized By: **David Castillo**, Program Coordinator
Fire Engineering & Investigations Division

TruWood[®]
SIDING | TRIM

© 2019 TruWood LLC. All rights reserved.



Look for our certified wood products
FSC® - C002971

TREATED WITH
EcoGuard[®]
ZINC BORATE



30

YEAR WARRANTY
LIMITED
TRANSFERABLE