



Installation Instructions for Premium Lap Siding

Includes: 4 in., 5 in., 8 in. Cottage Lap®
TwelveFour Cottage Lap®
TwelveSix Cottage Lap®
and Channel Rustic

Important:

Read and understand all pages of the installation instructions before starting the siding application.

For TruWood care and maintenance information, warranty information, and installation videos, visit our web site at: TruWoodSiding.com

FRAMING

- Apply these lap siding products horizontally on walls and gables that meet racking requirements.
- Follow product specific nailing pattern (see Fig. 4).
- Framing must not exceed 16 in. on center (o.c.).
- Although not recommended, where 24 in. o.c. vertical framing is used, nail to framing 24 in. o.c. with intermediate nailing 12 in. o.c. to sheathing with a 6d galvanized ring shank nail. This effectively creates a 12 in. o.c. nailing schedule.

SHEATHING

- Sheathing is required for all siding products. Recommended sheathing is a minimum of 7/16 in. OSB or 1/2 in. exterior grade plywood.
- Foam sheathing or other composite sheathing may be substituted. Collins Products LLC will not be responsible for problems related to crushing of the foam during or after siding applications, or moisture accumulation in the wall cavity.

VAPOR BARRIERS, VENTILATION AND MOISTURE CONTROL

- Roofs, gutters, roof to wall transitions, windows, doors, decks and attachments shall be designed, flashed and installed to prevent moisture entry into the siding or wall cavity or accumulation of water against the siding other than ambient moisture.
- Siding must have 2 in. clearance from masonry, concrete, brick, stone, stucco or mortar, or be properly flashed (see Fig. 7).
- A continuous vapor barrier rated 1 perm or less is required across the interior side of all walls to be sided.
- A vapor barrier rated 1 perm or less must be installed between the wood sill, wood framing and the foundation wall.
- A vapor barrier ground cover must be used in crawl spaces.

- Crawl spaces, attics and living spaces must be ventilated at least to the minimum specified in HUD standards.

FLASHING

- In areas where the bottom drip edge of the siding is adjacent to flashing, provide a minimum 3/8 in. gap between bottom drip edge of the siding and the flashing (see Fig. 7).
- Install flashing in a manner that creates proper out-sloping (see Fig. 7).
- Kick out flashing is required in areas where the roof and gutters are adjacent to the siding. Provide a 1 in. clearance between the gutter end and the siding (see Fig. 8).

INSTALLING

- Start by ripping 2 or more inches off the top edge of the premium lap siding. The bottom portions of the ripped siding may be used for the top courses. Align starter strip with the bottom edge of the sill plate.
- Make sure to prime and paint all exposed cut edges.
- 16 in. Cottage Lap and Channel Rustic Sidings require 3 nails per board on all studs 16 in. o.c.
- 12 in. Cottage Lap Sidings require 2 nails per board on studs 16 in. o.c.
- Place nails 5/8 in. to 3/4 in. up from the drip edge and in the center of the lap. Make sure that drip edge nails penetrate both courses of siding and into studs. Do not nail in the groove (see Fig. 4).
- Periodic checks are necessary to ensure the horizontal lap remains level. Make adjustments as necessary.
- Vertical butt joints must be located only on studs.
- When butting siding to inside or outside corners, use a minimum 1 in. thick dry wood material. TruWood Trim is recommended (see Fig. 3).

FASTENING

- Use corrosion resistant boxhead nails with a minimum head diameter of 1/4 in. (10% variance allowed).
- Fastening must not exceed 16 in. o.c. (see Framing section for 24 in. o.c. stud spacing).
- All lap products require that the butt joints be located on the studs and nailed at the joints (see Fig. 2).
- Nails must penetrate wood framing 1-1/2 in.
- Avoid countersinking nails or rupturing the surface of the siding. If countersinking occurs, seal nail prior to painting (see Fig. 1).
- Fasten from end to end or center to end to avoid internal stress.
- Nailing schedule for soffit application of siding products must not exceed 16 in. o.c.
- For siding used as soffit material, the siding must be nailed 12 in. or 16 in. o.c. into the framing.

GAPS AND CORNERS

- Leave 3/16 in. gap around all doors, window frames and corners. Seal all gaps (see Fig. 2 and 3).

BUTT JOINTS

- All butt joints must be located over studs.
- Leave 3/16 in. gap at all butt joints (see Fig. 2).

Stacked Butt Joints (see Fig. 5)

Vertically aligning butt joints at a common location on the wall is strongly recommended. Joints should be gapped at least 3/16 in., sealed, then vertical trim is applied over the joints. This method minimizes long term homeowner maintenance.

Staggered Butt Joints (see Fig. 6)

If butt joints are staggered, vertical butt joint covers are required to protect the butt joints. Sealing butt joints in lieu of joint covers is

permitted but not recommended as it requires a higher degree of homeowner maintenance.

CLEARANCES

- Siding must have a minimum 2 in. separation from concrete or be appropriately flashed.
- Siding must be 6 in. from soil or landscaping material.
- Where the siding meets the roof, it must be spaced a minimum of 2 in. from the plane of the roof and be properly flashed. The cut edge must be primed and painted.
- Vegetation must not be in direct contact with the siding.

SEALING

- Use the best quality flexible, paintable, mildew-resistant exterior grade sealant material that meets ASTM C920, Class 25 or higher.
- Seal around all openings such as window and door frames and at butt joints.
- Seal all overdriven nails (see Fig. 1)
- Seal or flash all horizontal trim material in a manner that creates proper out-sloping.

PAINTING

- Touch up damaged areas with premium acrylic latex primer or premium alkyd oil-based primer.
- Siding must be finish-painted within 90 days after installation. If siding is exposed for a longer period, reprime the siding.
- Siding must be clean and dry when paint is applied.
- Use only premium acrylic latex paint or premium alkyd oil-based paint containing an appropriate amount of mildewcide for local moisture conditions.
- For best performance, use 100% acrylic latex paints or 100% acrylic latex solid body (opaque) stain.

- Follow paint manufacturer’s recommendations for engineered wood siding.
- A minimum of 4 dry mils, which includes 1 mil factory primer, is required. This is best achieved with two coats of finished paint.
- Drip edges and grooves must be well coated.
- All surfaces and exposed cut edges must be painted in place.

PROPER STORAGE

- Store siding flat and support it on stringers to avoid sagging and contact with the ground.
- Siding must be covered and protected from the elements.
- Allow siding to acclimatize to local conditions prior to installation.

CONSTRUCTION ESSENTIALS

- The structure must be constructed to meet local applicable building requirements, HUD minimum property standards or HUD manufactured housing construction and safety standards. Lap siding does not provide shear strength.

WARRANTY REQUIREMENTS

- The terms of the Limited Warranty require strict compliance with the installation instructions. These instructions are supplemental to applicable local building codes and standard building practices. Compliance with the most stringent of these is required. Architectural designs, plans and specifications must comply with these instructions.
- All deviations from the installation instructions must be pre-approved in writing by the Collins Products LLC Product Performance Manager.

INSTALLATION ERRORS THAT VOID THE WARRANTY

- Do not apply siding to a rain soaked structure.
- Do not apply siding that is wet. Wet siding can shrink after application and shrinkage is not covered by the TruWood warranty.
- Wet blown insulation is not allowed.
- Do not apply stucco or composite stucco products over the siding.
- Do not apply the siding to floating structures or buildings over water.
- Staples are not an acceptable fastening device.
- Do not apply to wall systems without conventional framing.
- Do not bevel cut the siding edges at butt joints.
- Do not paint in wet or cold conditions.
- Do not use shake and shingle paints, low quality flat oil or alkyd paints, vinyl acetate (PVA), vinyl acrylic or vinyl acetate-acrylic co-polymer paints. These coatings do not adequately protect the siding.
- Do not blind nail siding.

Note: This list is not intended to be inclusive of all errors that would void the warranty. These are just some examples.

KEY HOMEOWNER MAINTENANCE RESPONSIBILITIES

- Inspect and renew all sealant and immediately repair any water penetration issues every year.
- Maintain gutters and downspouts to avoid water cascading down walls.
- Ensure sprinkler patterns are directed away from structures.
- Follow paint manufacturer’s recommendations for repainting and paint maintenance.

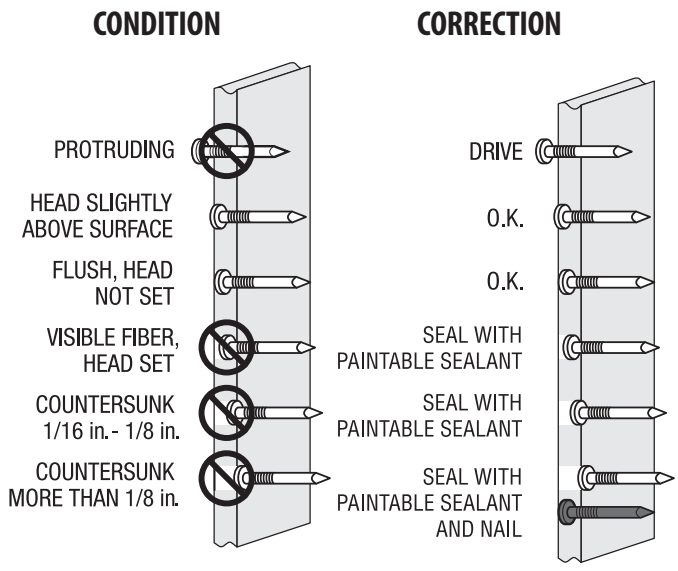

Figure 1

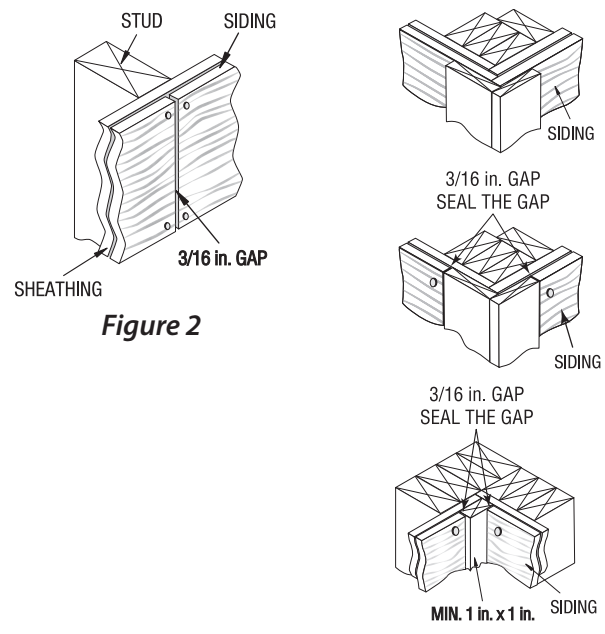

Figure 2

Figure 3

PREMIUM LAP SIDING NAILING

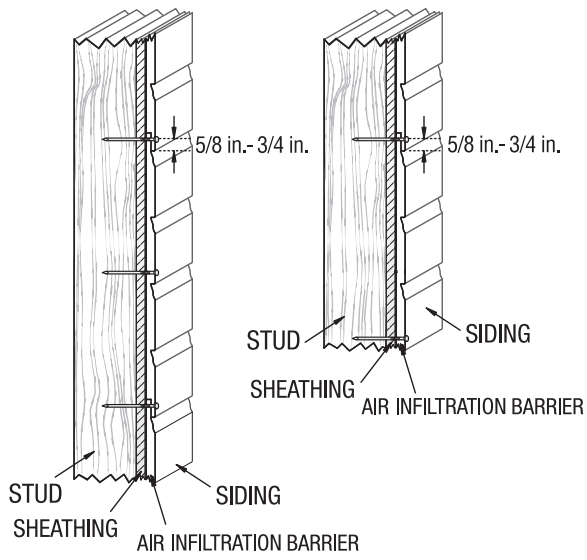

Figure 4

VERTICALLY ALIGNED JOINTS

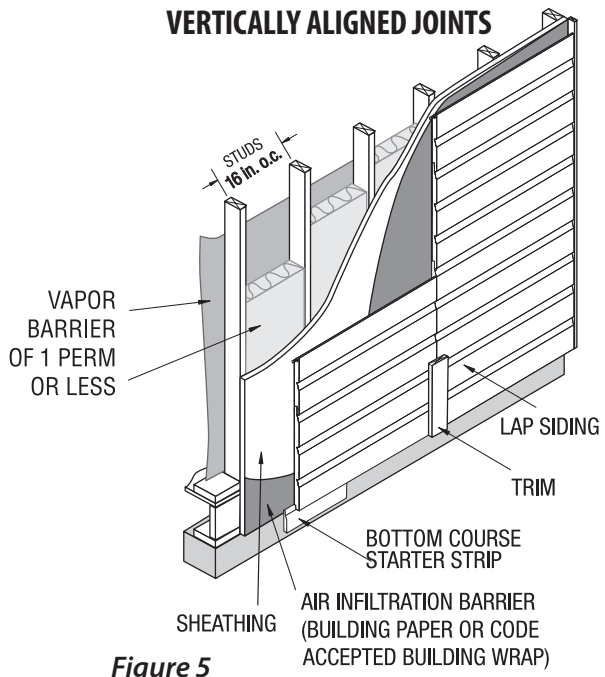

Figure 5

STAGGERED JOINTS

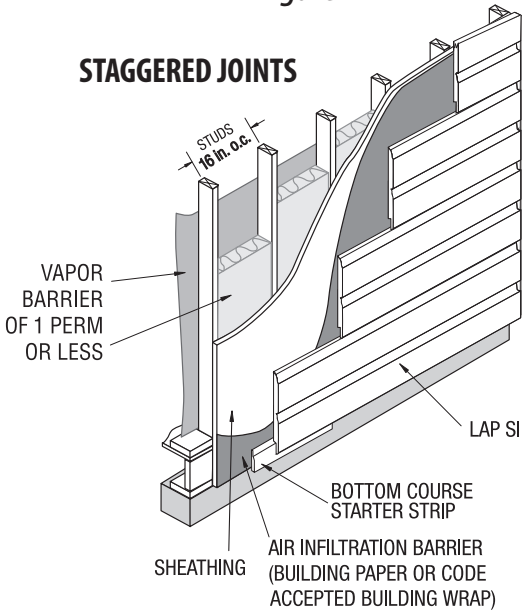

Figure 6

FLASHING

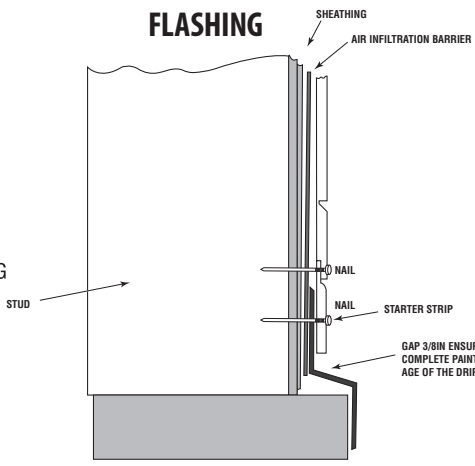

Figure 7

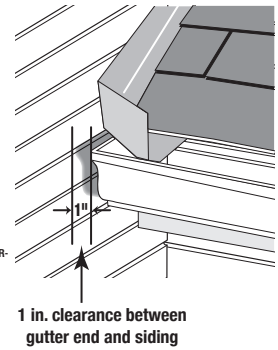

Figure 8

- Apply siding over approved structural sheathing.
- Maximum nail spacing is 16 in. on center.
- Nails must penetrate wood framing 1-1/2 in.
- Do not use staples. Use only the nails specified in these instructions.
- Install a minimum 3/16 in. gap at butt joints and ends. Use only approved methods to protect joints areas.
- Siding must not be in direct contact with stucco, mortar, stone, brick, concrete or masonry.
- Apply siding in a method that will prevent moisture entry into the siding or wall cavity.
- Seal all exposed cut ends using a method that will prevent moisture intrusion.
- Maintain the proper clearance from the siding bottom drip edge to the finished grade, walkways and adjacent to the roof lines.

CODES AND STANDARDS

TruWood® Siding meets the requirements of the following codes and standards:

- 2021 International Building Code
- 2021 International Residential Code
- ICC ESR-2588
- American National Standard
ANSI-CPA 135.6 – 2012
- California Wildland-Urban Interface (WUI)*

***CALIFORNIA WUI APPLICATION REQUIREMENTS**

- Framing must not exceed 16 in. on center.
- Minimum 5/8 in. Type-X gypsum exterior sheathing is required.

(8140-2025:0006SFM 12-7A-1)

Sales: 800.417.3674 • Warranty: 800.329.1219 • TruWoodSiding.com